



Industrial applications of acoustic camera

Kiril Alexiev

alexiev@bas.bg

Pavia, 2018

Acknowledgements

The preparation of this presentation and lecture in the University of Pavia are supported by **Erasmus+** program under Mobility Agreement “**Staff Mobility For Teaching**” between Bulgarian Academy of Sciences (Erasmus code BG SOFIA30) and University of Pavia (Erasmus code I PAVIA01).

Mathematical Methods for Sensor Information Processing Department



A little history

The Department was established about 30 years ago for R&D in Bulgarian industry and military electronics. Almost all Bulgarian serial manufactured radars for meteorological, air-defence and marine surface surveillance were developed with participation of the members from our team. We participated also in R&D of new military communication systems.



Since 1987 the team was moved in Bulgarian Academy of Sciences in a newly established department named “Mathematical methods for sensor information processing”. The main idea was by employing complex mathematical approaches on high performance computers to solve basic problems of sensor systems like:

- Artificial Intelligence;
- Multiple sensor data fusion;
- Change detection, behaviour estimation;
- Data association problems;
- Estimation of non-linear and non-Gaussian dynamic systems, etc.

- 
- Annually we publish about 20 peer-reviewed papers, most of them in journals with IF or SJR;
 - We had several successfully graduated PhD students, and several PhD students, which were going to finish their theses ... somewhere in Europe and Canada;
 - We had 3 Postdocs – one from Bristol University, England; one from Kharkov, Ukraine and another one from Kiev, Ukraine;
 - Two of us are participating actively in educational process at the Universities having regular courses;
 - Every year many students conducted their practice in the department, now we have two of them appointed on temporary contracts;

- We have regular thematic interdisciplinary seminar;
- In the last 5 years we have organized regularly annual symposiums in the framework of bigger international conferences and one IEEE conference on intelligent applications;
- All scientists are members of different Bulgarian and international scientific professional organisation like IEEE, ISIF, UAI, UMB, etc.,
- We organized one NATO ASI and participated in several others NATO ASI on the hot topics of research; A year ago we organized a meeting on radars (NATO series)
- We participated in two COST actions;
- We have well-established scientific collaboration with colleagues from ONERA – France, from the University of Bradford, Lancaster University in England, University of Sheffield, “Lucian Blaga”- University of Sibiu, University of Pavia and etc.

Currently running projects

- Mathematical methods for sensor information processing – budget;
- Modelling Of Voluntary Saccadic Eye Movements During Decision Making, contract No DFNI – DN02/3 with Bulgarian Science Fund, 2016-2019.
- Operating program BG16RFOP002-1.005 “Development of inovative products and technologies”, Contract BG16RFO002-1.005-0163 “Inovative service for automatic search and organization of big scales of personal photos” – 2018-2020.
- Center for Excellence in Informatics and Information and Communication Technologies 2018-2023.

Equipment – acoustic camera

Acoustic camera produced by *Brüel & Kjær (Sound and Vibration Measurement A/S)*. The device includes:

- 18 precision array microphones (10 Hz – 20 kHz) in an array with a diameter about 0.33 m;
- input modules;
- laptop with software;
- optic camera.

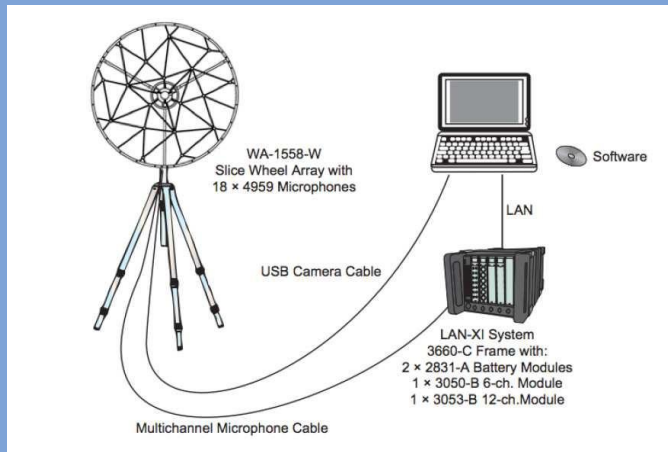

ID	Module
1.	3660-C-000 5 slot Mainframe LAN-XI
2.	3050-B-060 6-ch Input Module LAN-XI 51.2kHz (CCLD, V)
3.	3053-B-120 12-ch Input Module LAN-XI 25.6kHz (CCLD, V)
4.	3099-A-N1 PULSE LAN-XI Single Module Front-End Driver
5.	UA-2145 Array Front Panel LAN-XI Modules
6.	8607-N PULSE Array Acoustic Holography
7.	7761-N PULSE Acoustic Test Consultant
8.	BZ-5637-N PULSE Array Acoustic Conformal Calculations
9.	WA-1558-P-1CH Sector Wheel Beam Forming and SONAH array, Size 0.55-1.5 m, Channels 36, 60, 84, 108
10.	4959 Very Short Array Microphone for Handheld Arrays
11.	4228 Pistonphone calibrator, 250 Hz, 124 dB, Class 0
12.	WA-0728-W-003 Adaptor for 6-Channel Pistonphone, short version for all Array Microphones

Hardware – acoustic camera



Applications 1

- Noise pollution
 - Airport noise
 - Urban/Street noise
 - Instrument noise
- Noise identification. Find the source of specific noise
 - Sound quality analysis
 - Data/music recording
 - Multimedia product analysis
- Production testing and machine diagnostics by spectral analysis, time-frequency analysis, trend detection in sound intensity signals, noise intensity analysis, shock response analysis, without disassembling.
 - machine noise localization and analysis (turbines, car engine, etc.)
 - vibration testing

Applications 2

- Occupational health
 - Noise exposure
 - Hearing protection
 - Human vibration
 - Noise reduction
 - Factory hall acoustic
- Military/security applications
 - noise barrier detectors
 - noise localization
 - noise recognition
- Scientific tool for research in
 - beamforming
 - random antenna array development
 - acoustic signal analysis
 - acoustic holography
 - signal processing/filtering

Acoustic camera modes:

- Beam forming
- Acoustic holography

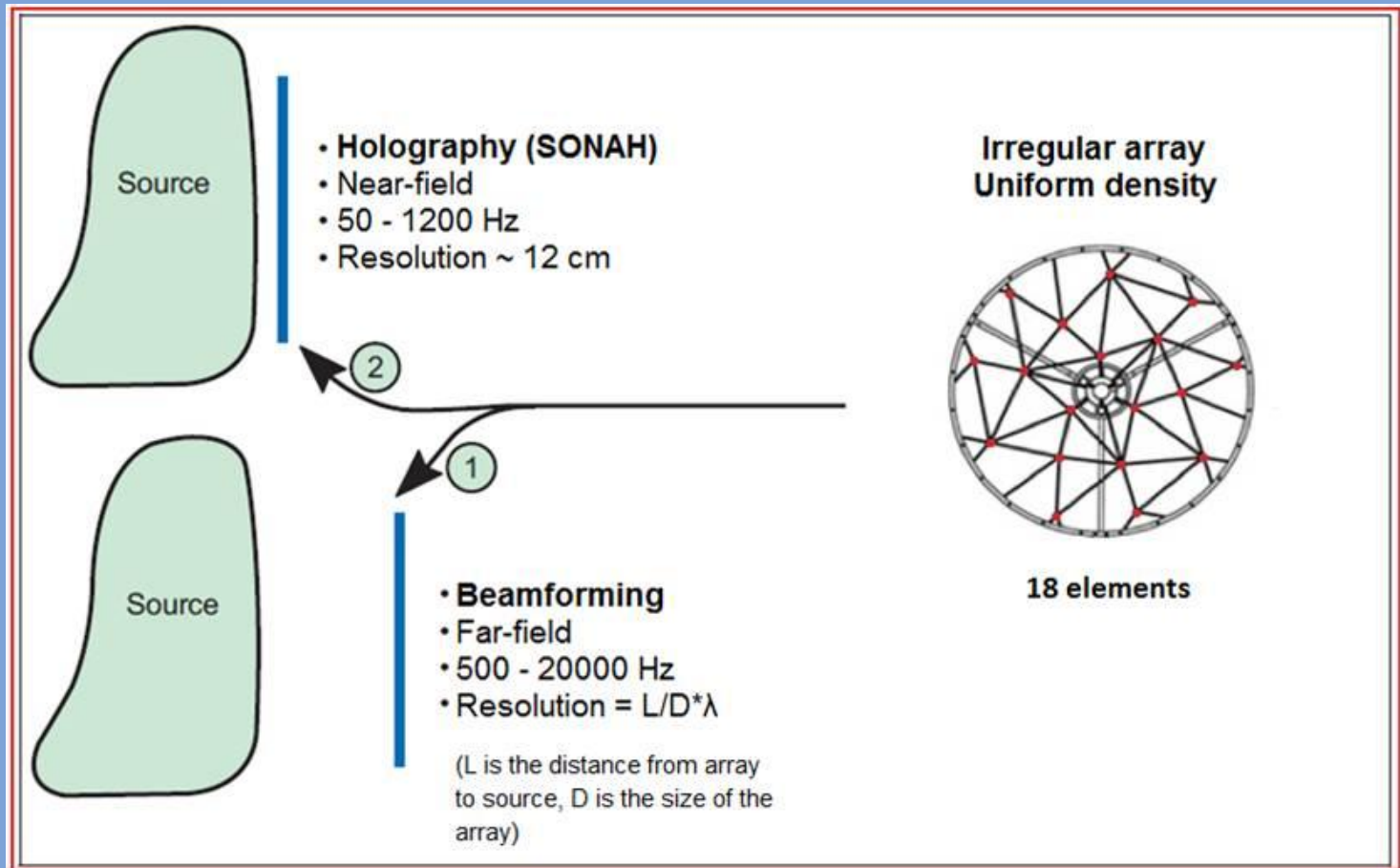

Beam forming

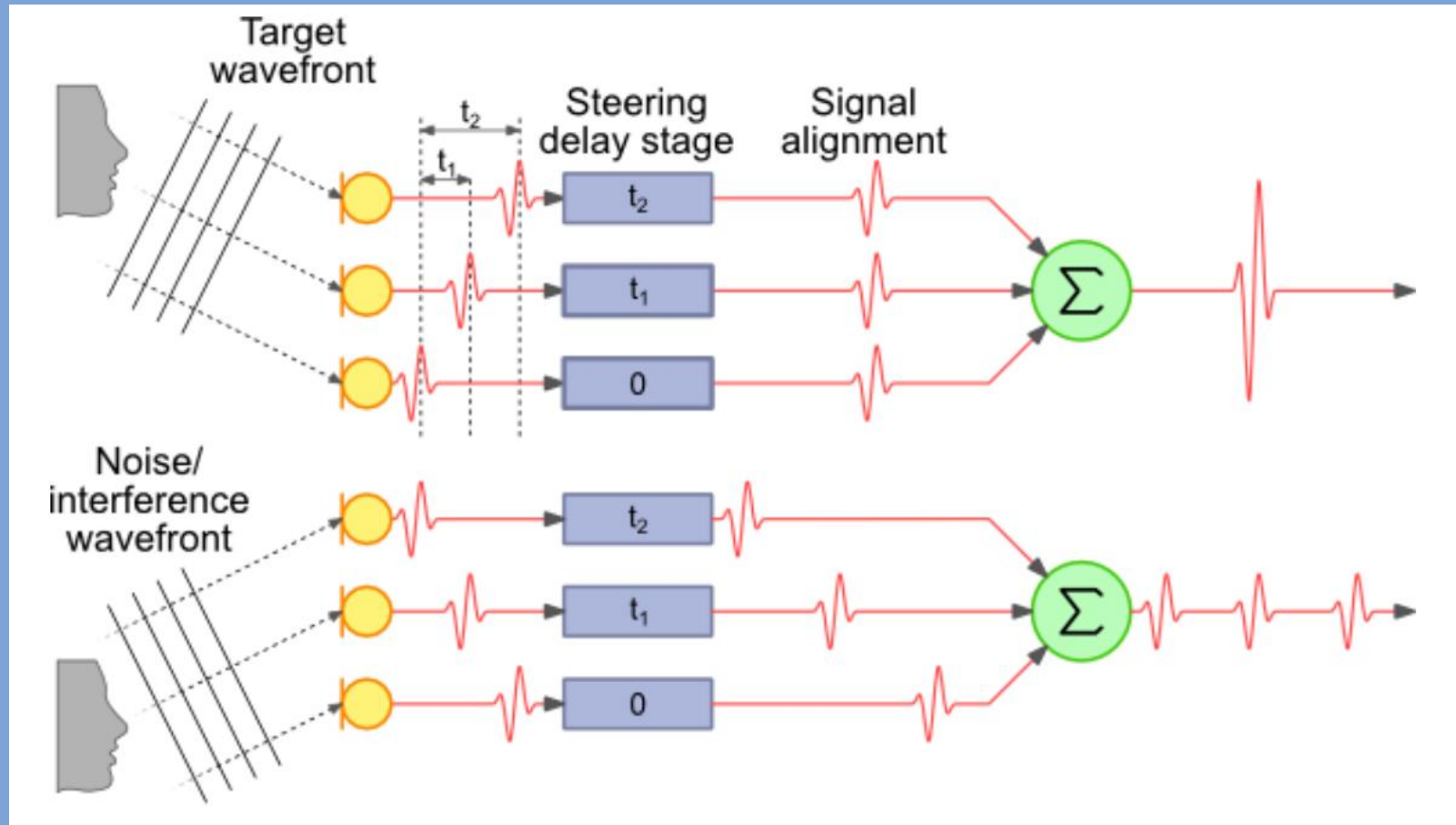

Beam pattern in polar coordinates

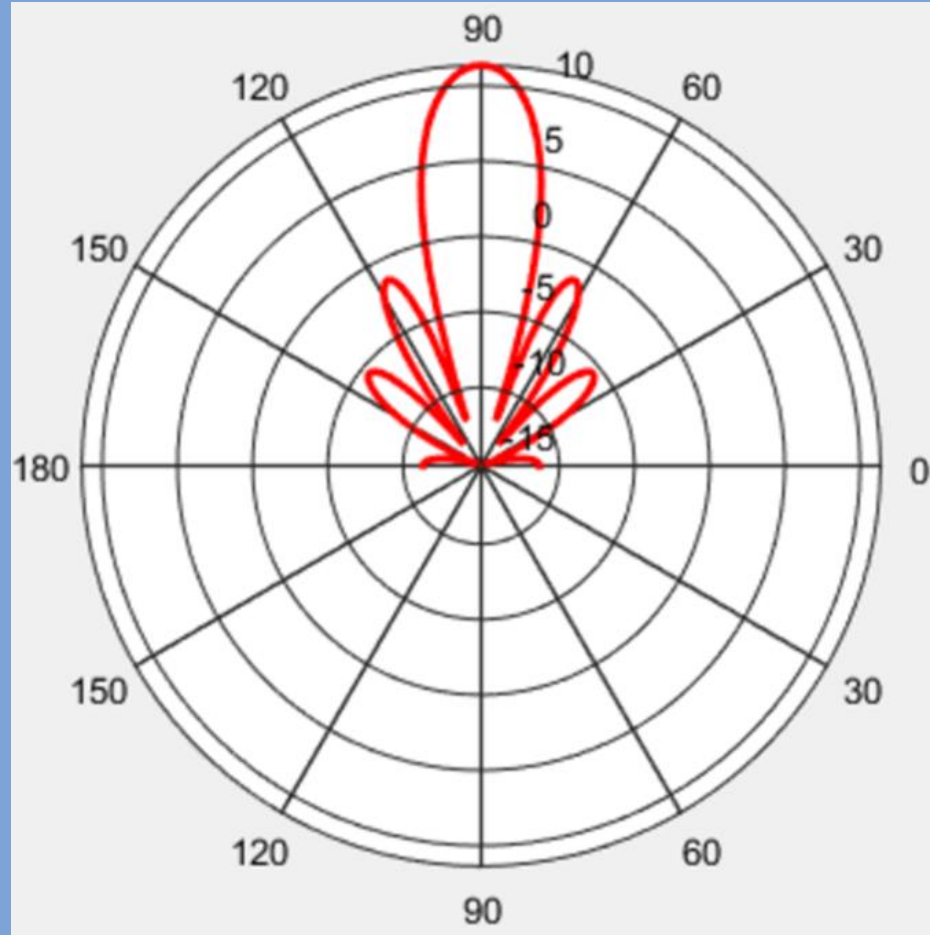

$$d=0.5\lambda$$

Pure antenna pattern

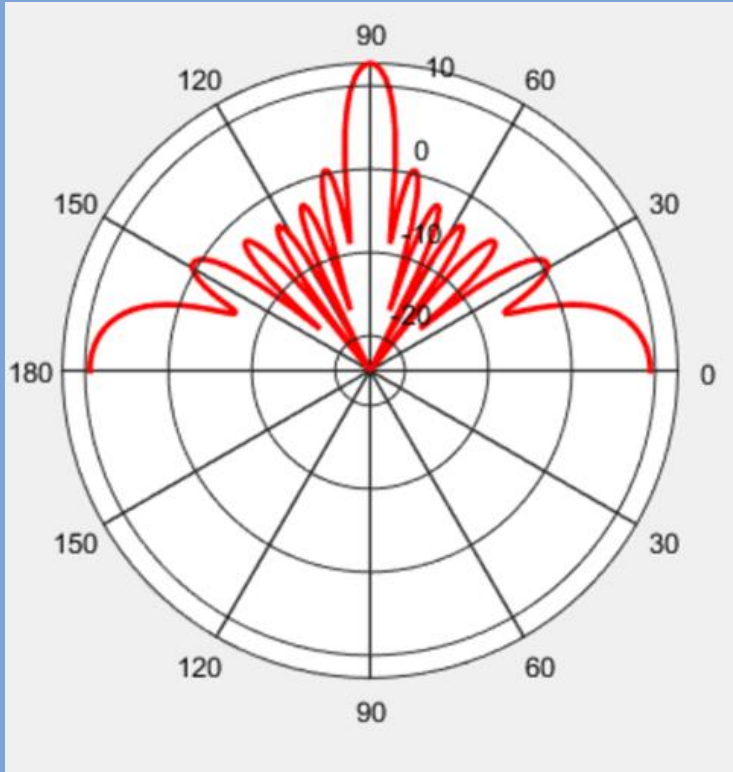

$d = \lambda$

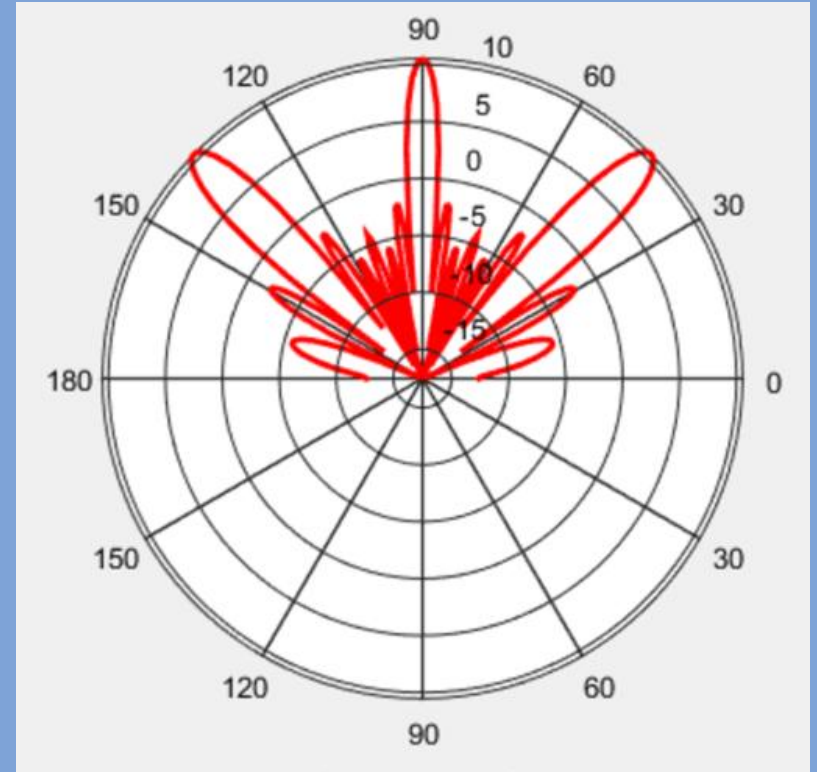

$d = 1.5\lambda$

Acoustic Camera Characteristics

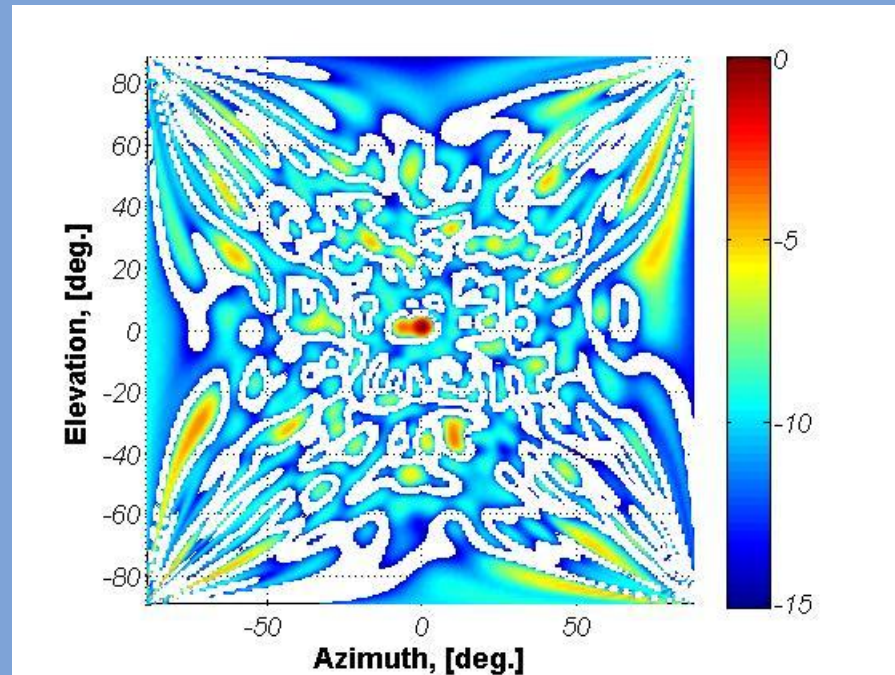

Two noise sources at 10 cm on 75 cm from the antenna

Acoustic Camera Characteristics

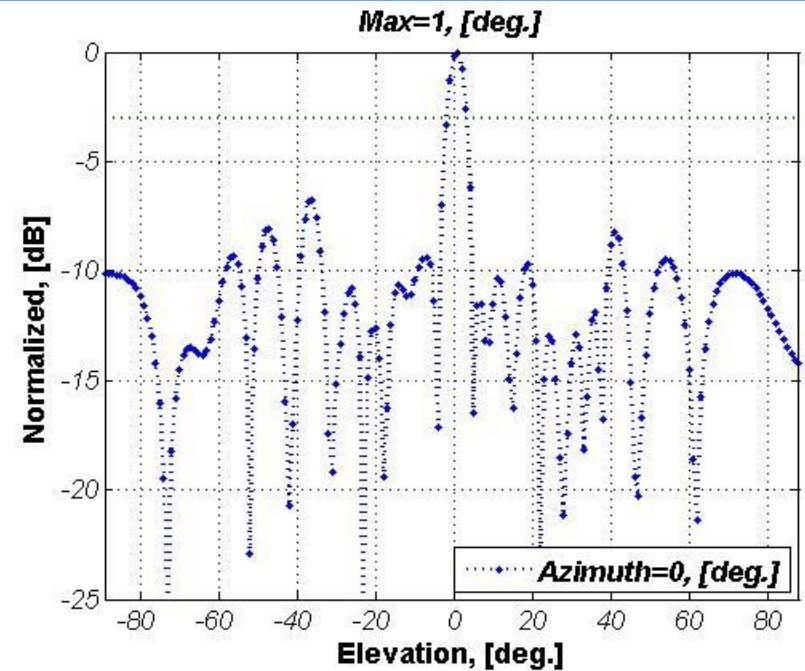
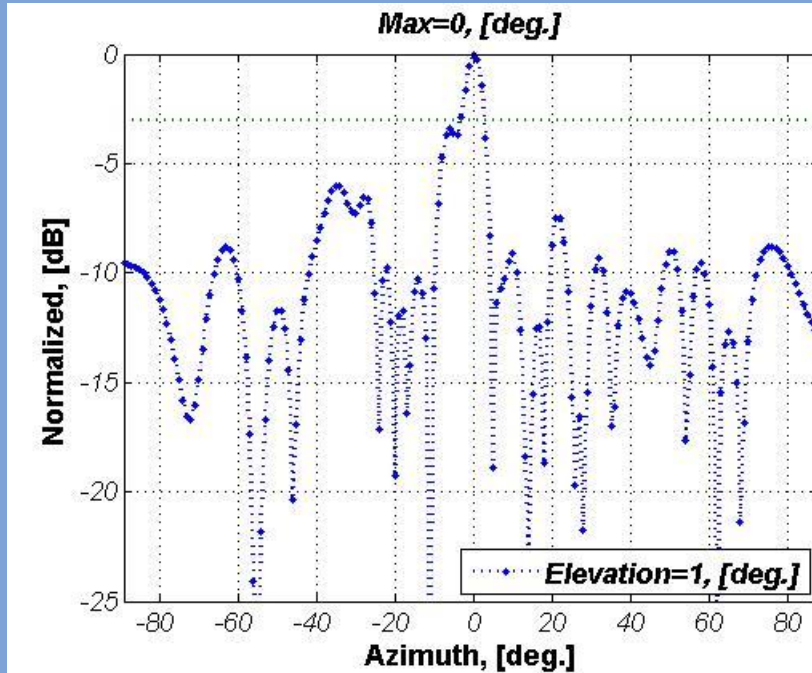



Object: KEMET Electronics Kyustendil, Bulgaria

Researchers: *Volodymyr V. Kudriashov¹, Vladislav V. Ivanov², Kiril M. Alexiev¹*

1: Transport Faculty of Technical University of Sofia;

2: Mathematical Methods for Sensor Information Processing
Department, Institute of Information and Communication Technologies,
Bulgarian Academy of Sciences

Electric Motor

The motor has an acoustic noise source, after replacement of the “front” bearing (Figure 1).

The estimate of the acoustic noise incoming from the source is $38.7 - 79.6 \text{ dB}_{20\text{mkPa}}$ at “center” frequencies 50 Hz – 16 kHz (Figure 1, the spectrum at “bottom left”).

Later it was detected, that the noise had appeared after welding front cover.

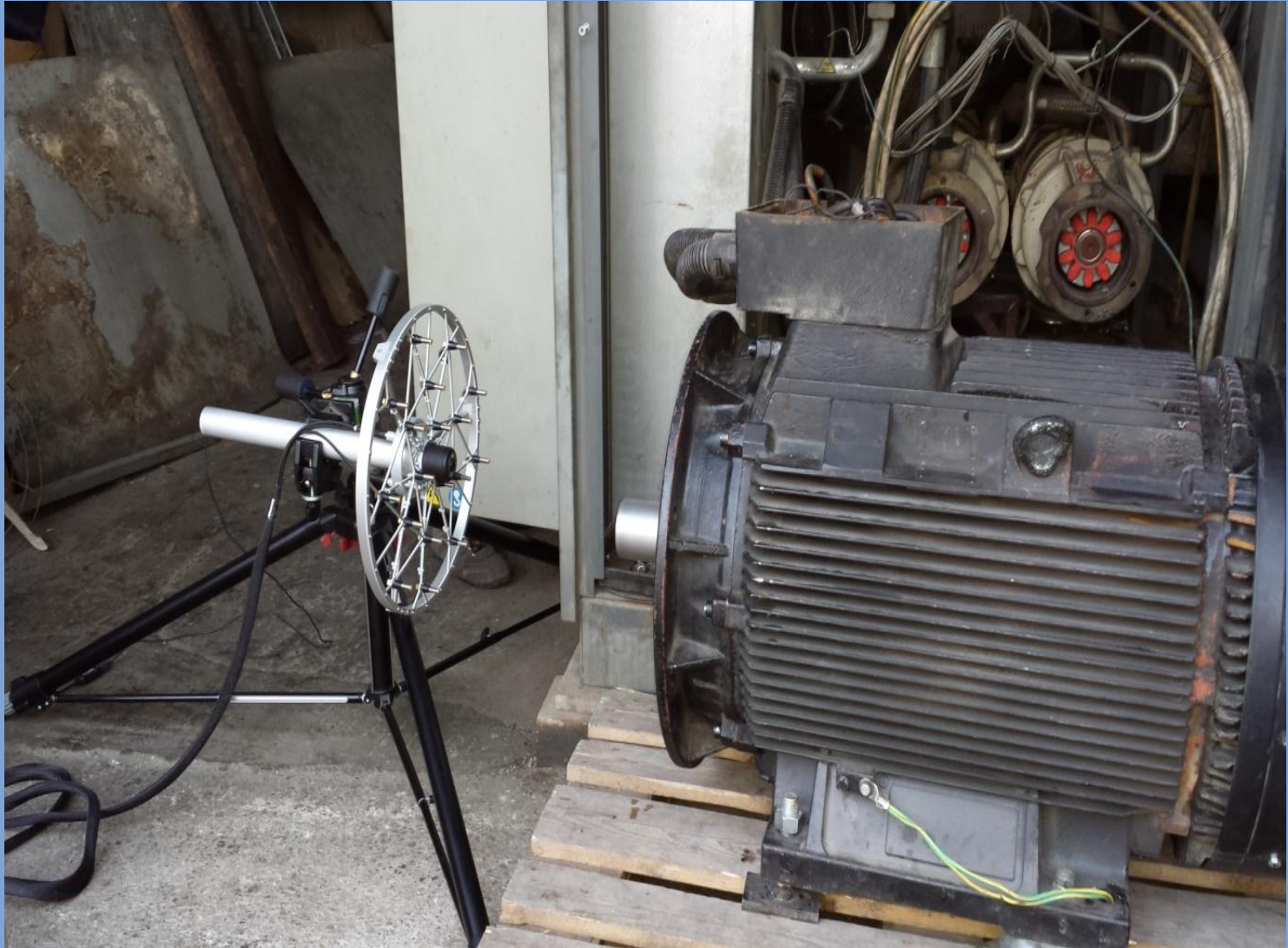

Acoustic camera data

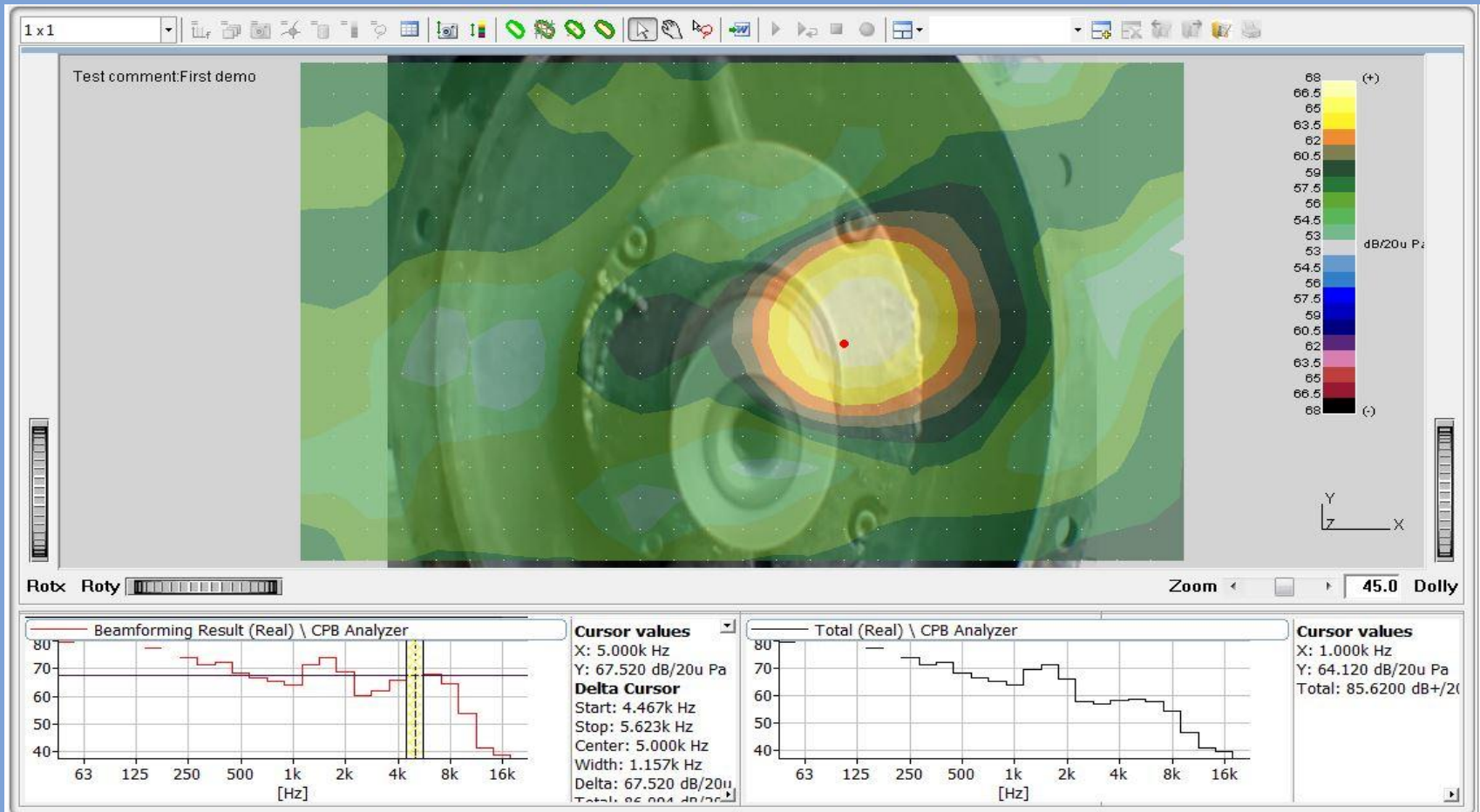

Measured

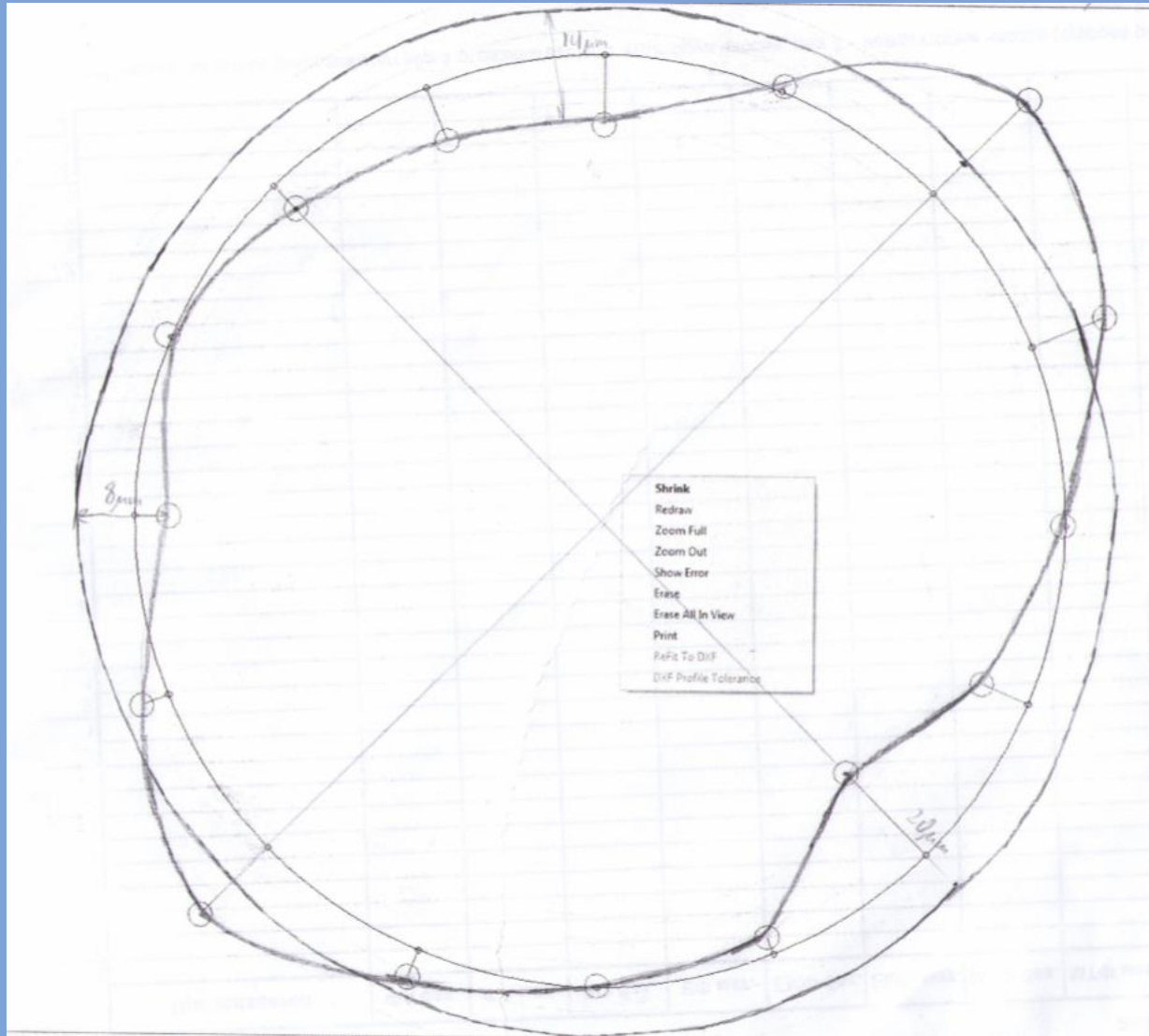

Summary

The front cover were dismantled and measured by 3D measurement tool. It was proved that at the pointed place there is cover deformation which leads to increased level of noise and accelerated failure of front bearing. The most possible reason for cover deformation is welding repair with uncontrolled heating.

A Vacuum Generator

The measurements detected following acoustic noise sources: two motors and wheel at the left side of mechanical part of the installation.

The acoustic noise was measured three times.

First two measurements (Rec. 874, 901) were carried out when the motor was switched off (for estimation of interfering background acoustic noise).

The 3rd measurement (Rec. 898) estimated acoustic noise of both the motor and the background.

Measured Noise ~10kHz

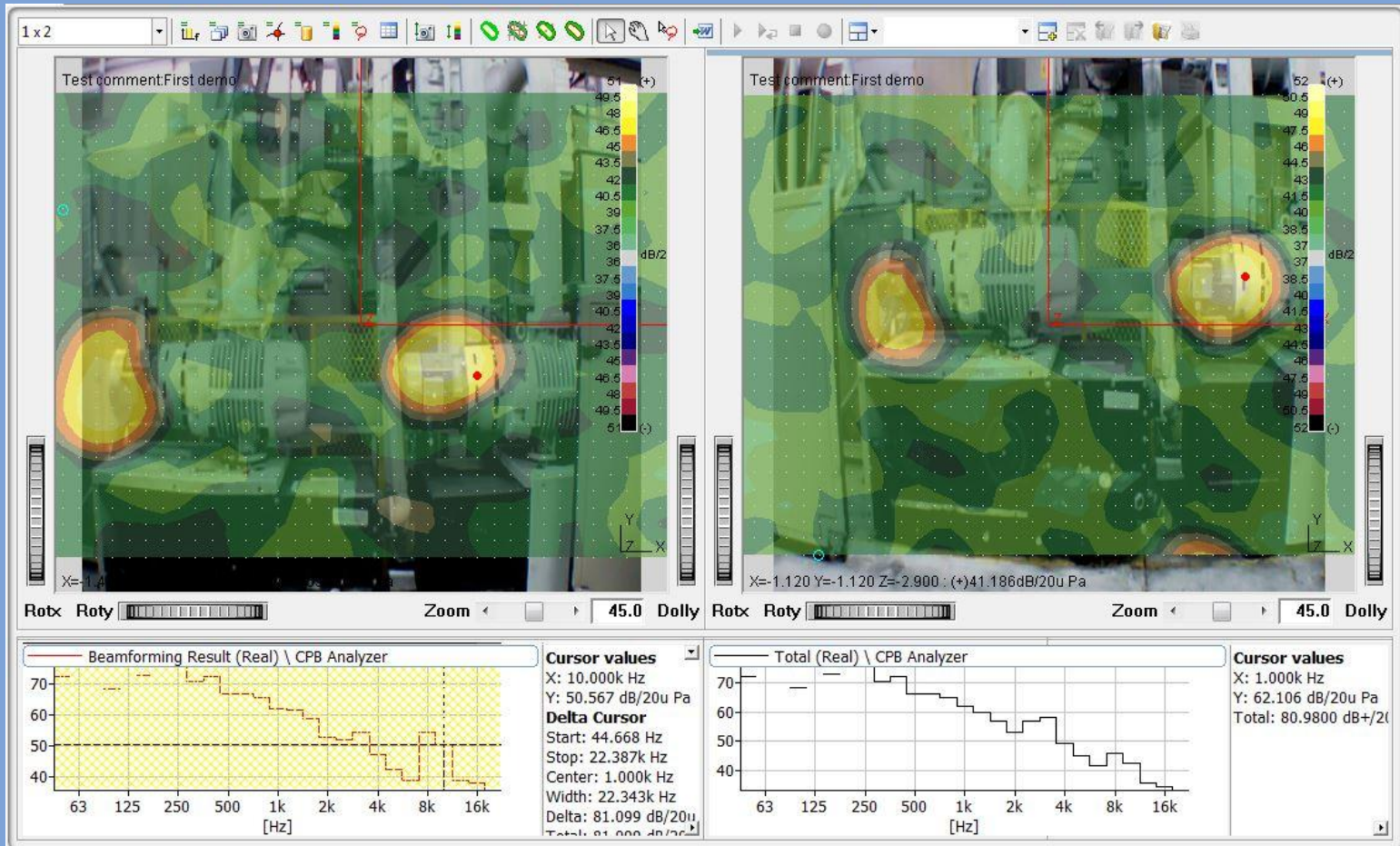

A Vacuum Generator

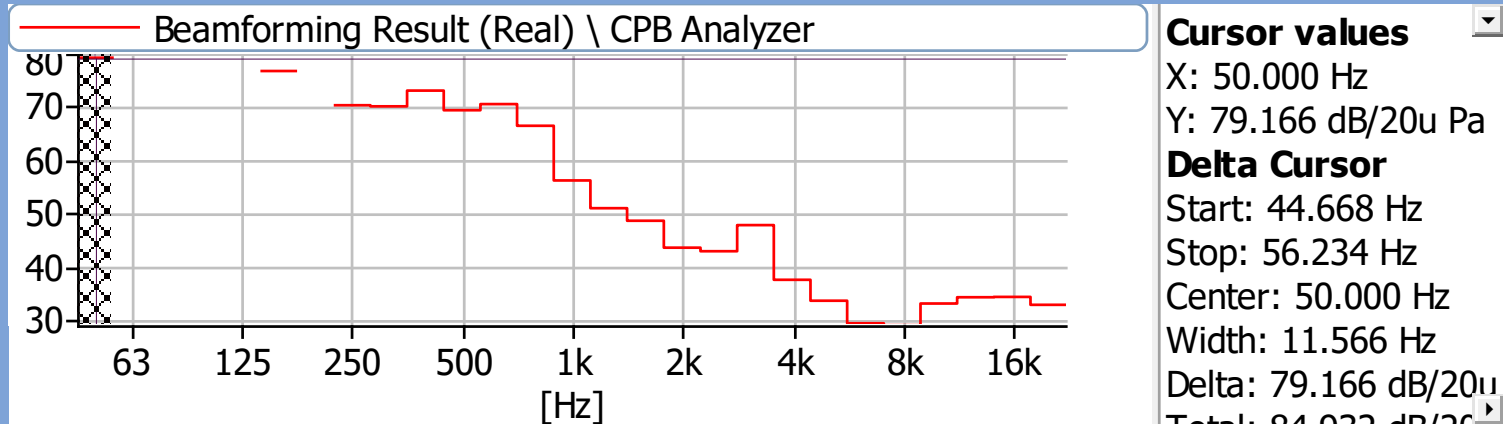

a) the motor is switched off;

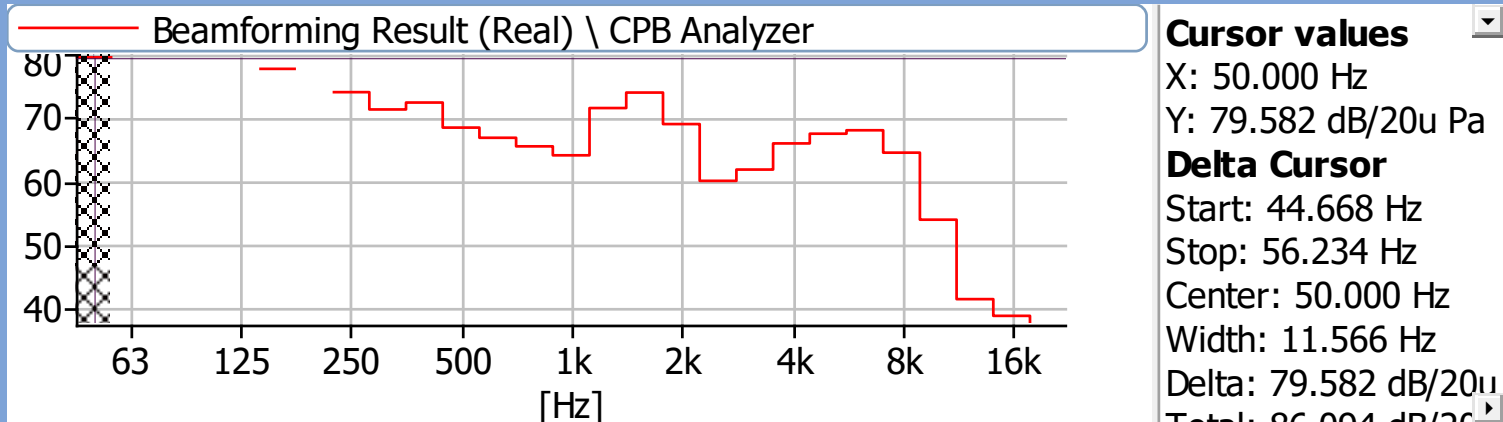

b) the motor is switched on.

The spectra of main noise source

Measured noise ~2.8 kHz

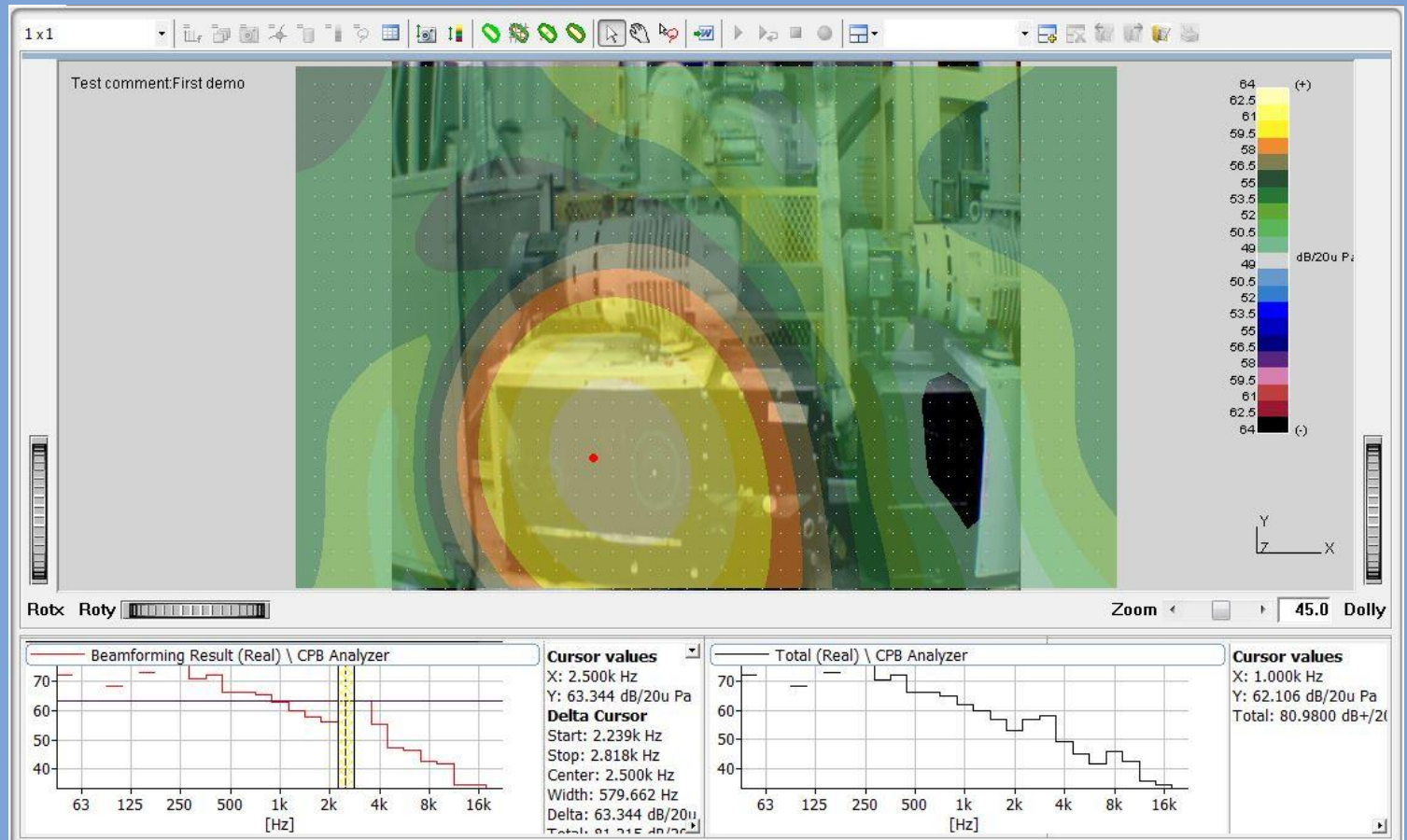

A Vacuum Generator

The acoustic noise from motor increases about 33 dB (4 dB), at center frequency 5 kHz (1 kHz) when the motor is switched on. The frequency of this “difference” depends on:

- (i) a spectrum of acoustic noise of the motor,
- (ii) a decreasing of the directivity of the microphone array with decreasing of the center frequency,
- (iii) other factors.

With respect to the directivity of the microphone array, the measurements have fine quality, at a high frequencies (above 1 kHz, roughly).

Mechanical part (a belt drive and three wheels)

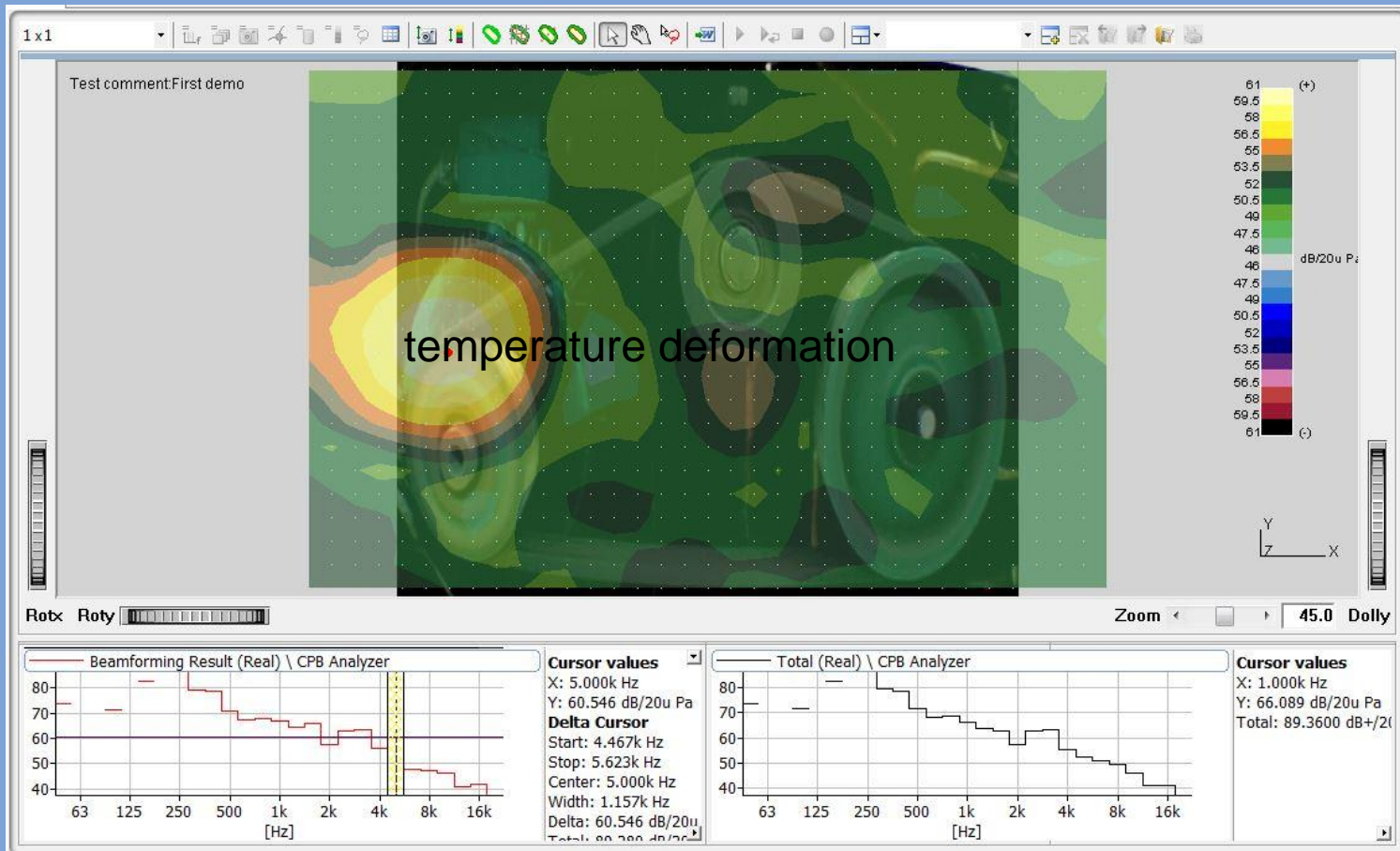

Summary

The noise from vacuum generator corresponds to the sources (electrical engines) and their revolutions per minute. The only suspicious noise, generated by the belt drive is concentrated on one of the wheel. The bearing condition of this wheel has to be checked.

"Леми Трафо"

Researchers: *Petia Koprinkova*¹, *Kiril M. Alexiev*¹

1: Mathematical Methods for Sensor Information Processing Department, Institute of Information and Communication Technologies, Bulgarian Academy of Sciences

The problem

The measuring of generated noise from power transformer without load (the noisiest regime of work) were carried out in acoustic isolated room. However, the acoustic room faded significantly industrial noise, without removing entirely it.

Measurement room



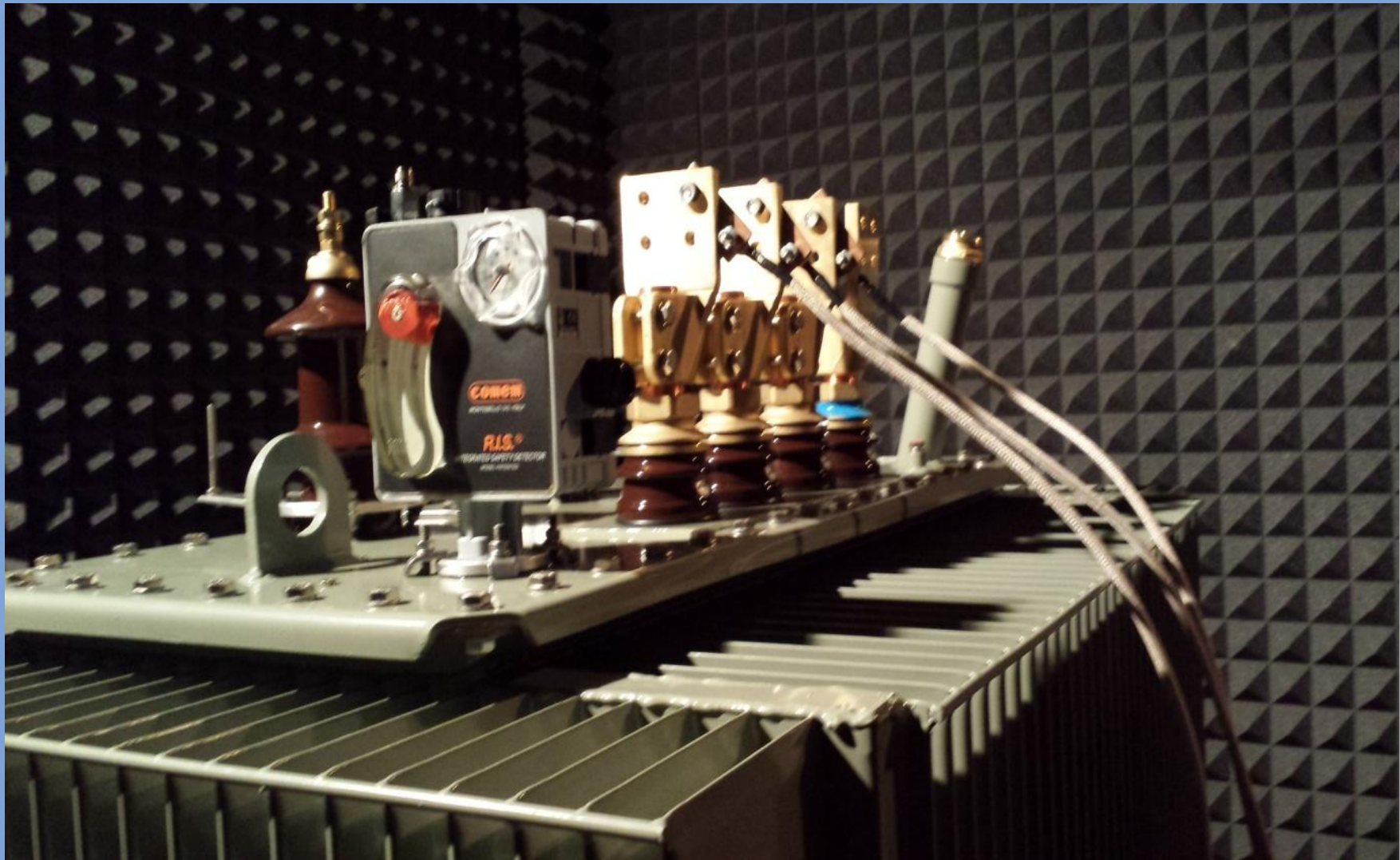

Background noise

Test comment: First demo

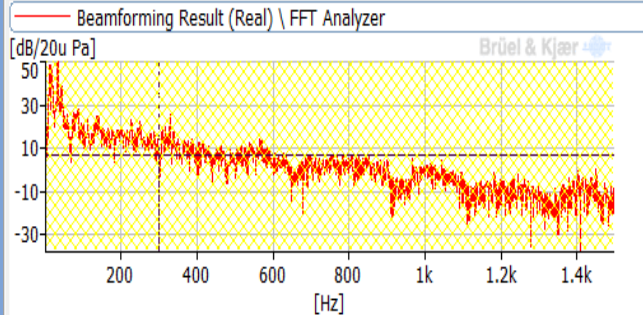
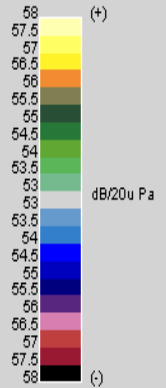
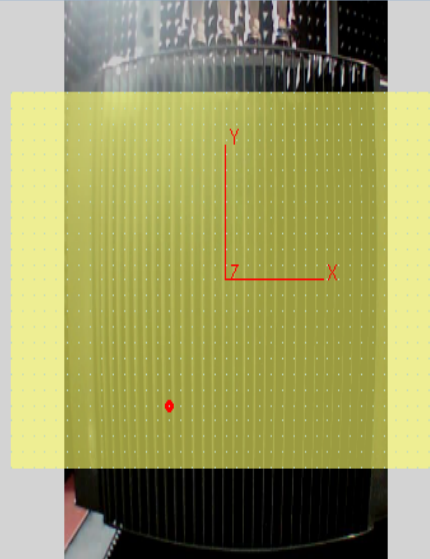

Cursor values
X: 300.000 Hz
Y: 6.705 dB/20u Pa
Delta Cursor
Start: 0.500 Hz
Stop: 1.500k Hz
Center: 750.500 Hz
Width: 1.500k Hz
Delta: 57.257 dB/20u Pa
Total: 57.257 dB/20u Pa
Delta/Total: 0 dB

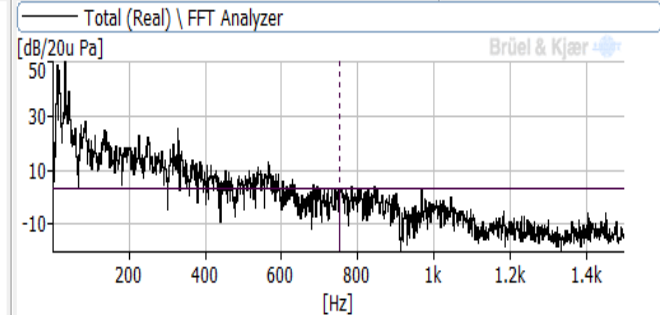

Cursor values
X: 751.000 Hz
Y: 3.283 dB/20u Pa
Total: 57.2500 dB+/20u Pa

Frontal noise

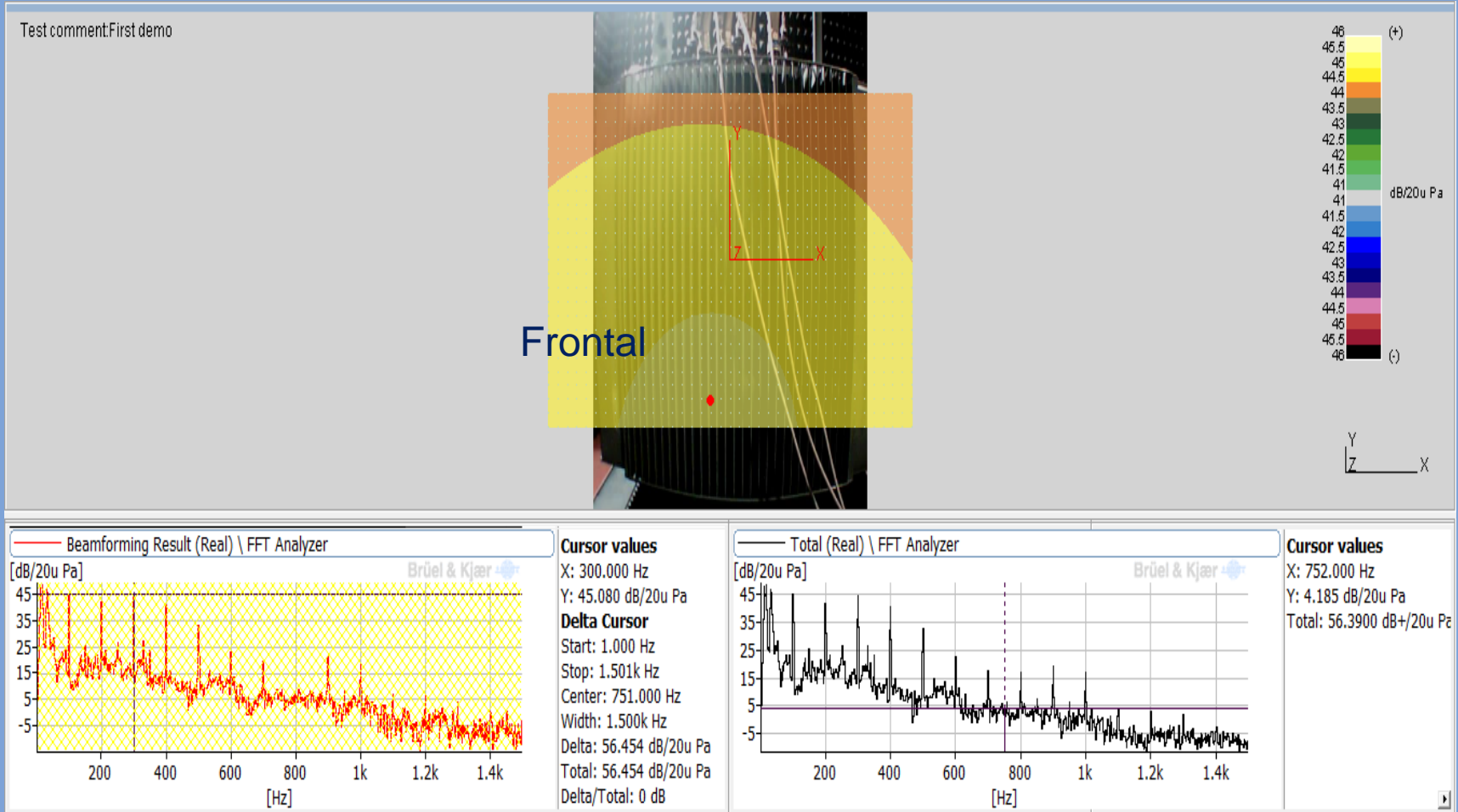

Side noise (right)

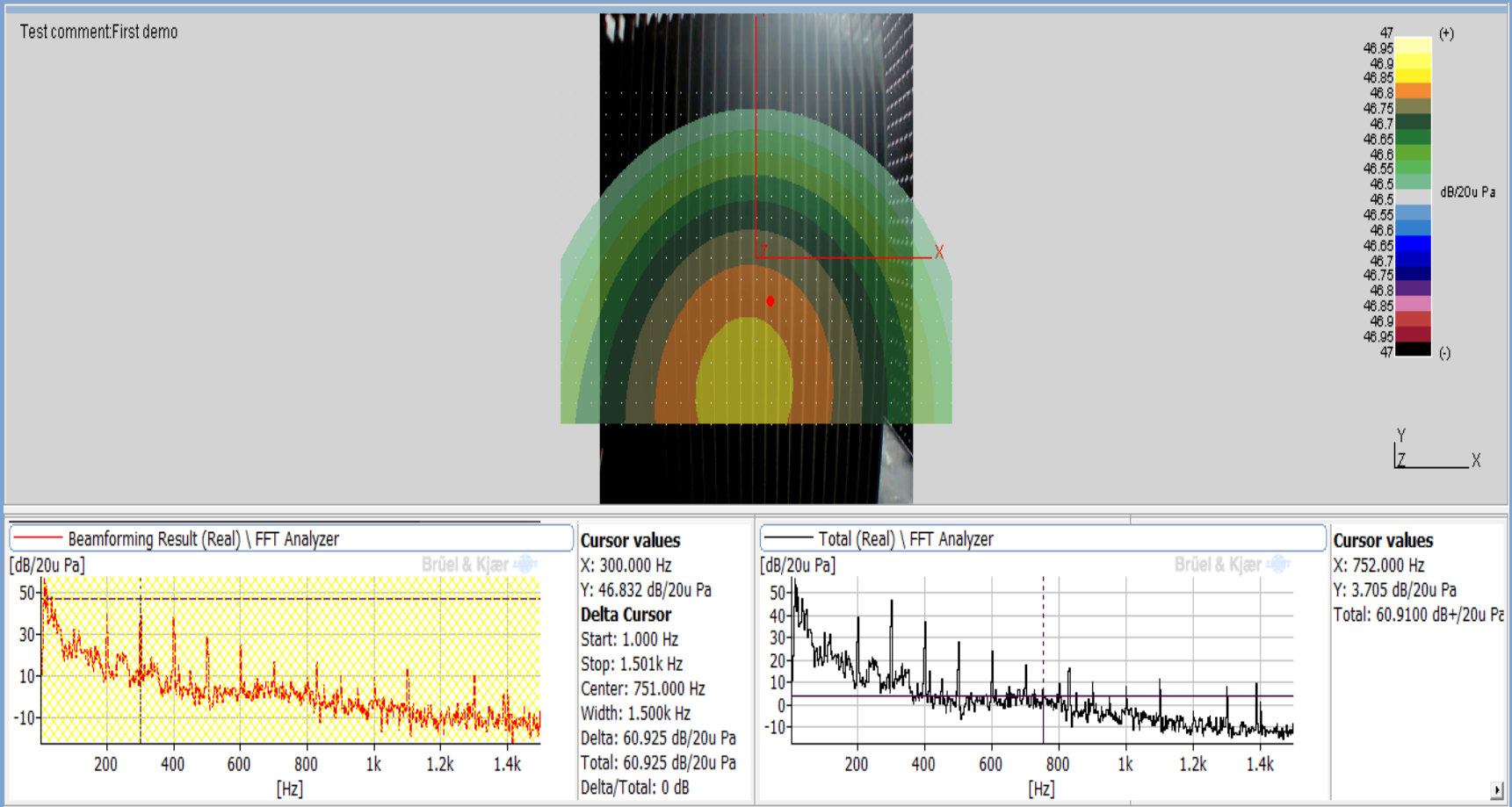

Side noise (left)

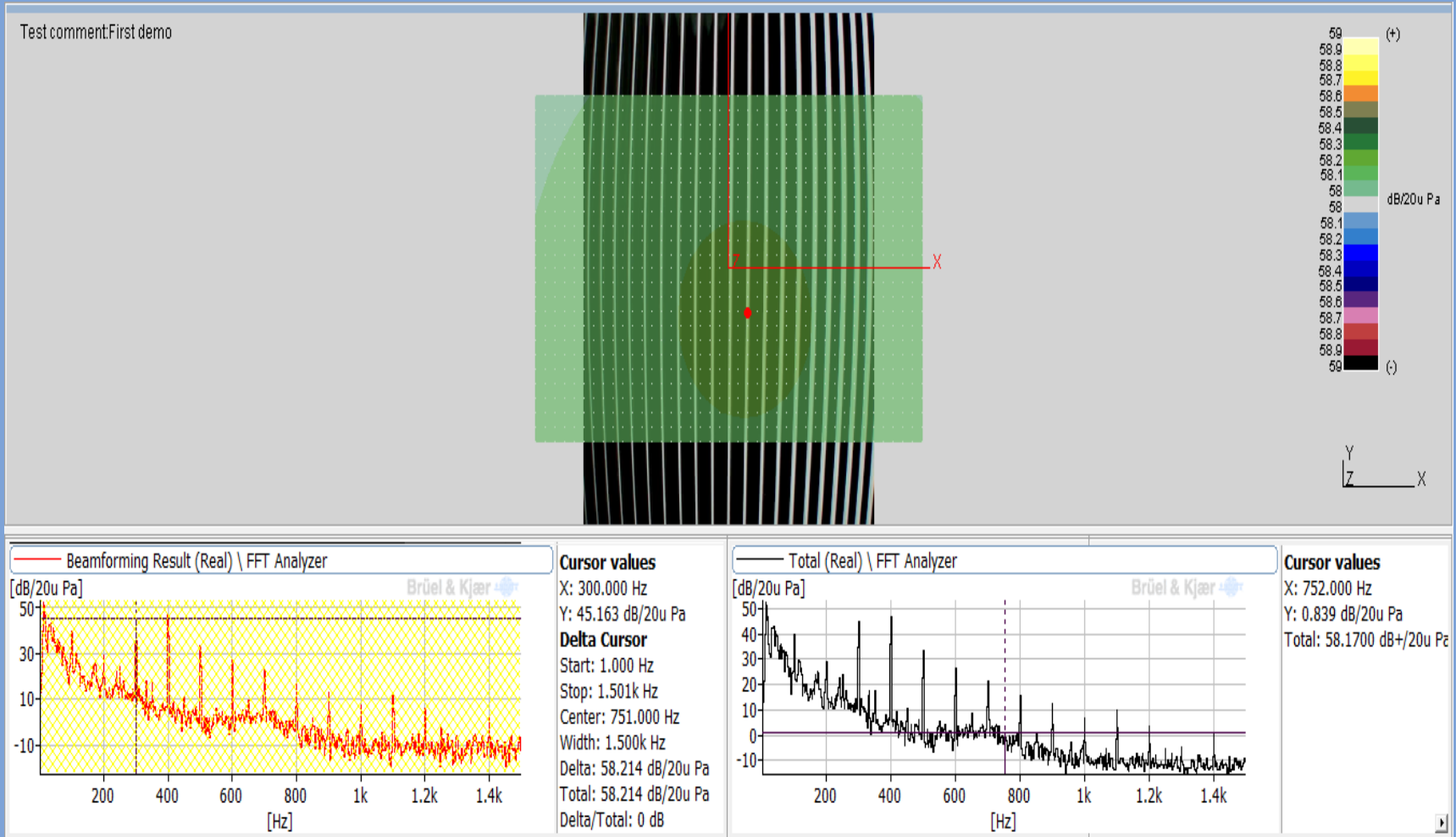

Summary

The noise level of measured transformer is 3-5 dB. It is important to note, that all harmonics of 100Hz have a level, about 30 dB higher than the rest of spectrum. The noise level is fading for frequencies 600 Hz and more.

Remark: the antenna accuracy for noise source localization at frequencies lower than 600 Hz is poor!

Solvay Sodi, Devnya

Researchers: *Volodymyr V. Kudriashov¹, Kiril M. Alexiev¹*

1: Mathematical Methods for Sensor Information Processing Department, Institute of Information and Communication Technologies, Bulgarian Academy of Sciences



Problem

The noise level of steam generator exceeds 110 dB and the environment is not “friendly” for the workers around.

Object – steam generator





The acoustic noise was measured from seven positions. The first five measurements enabled to localize the main noise sources of the steam generator installation. The last two measurements were focused on noise emissions of several of the localized sources.

Measurements

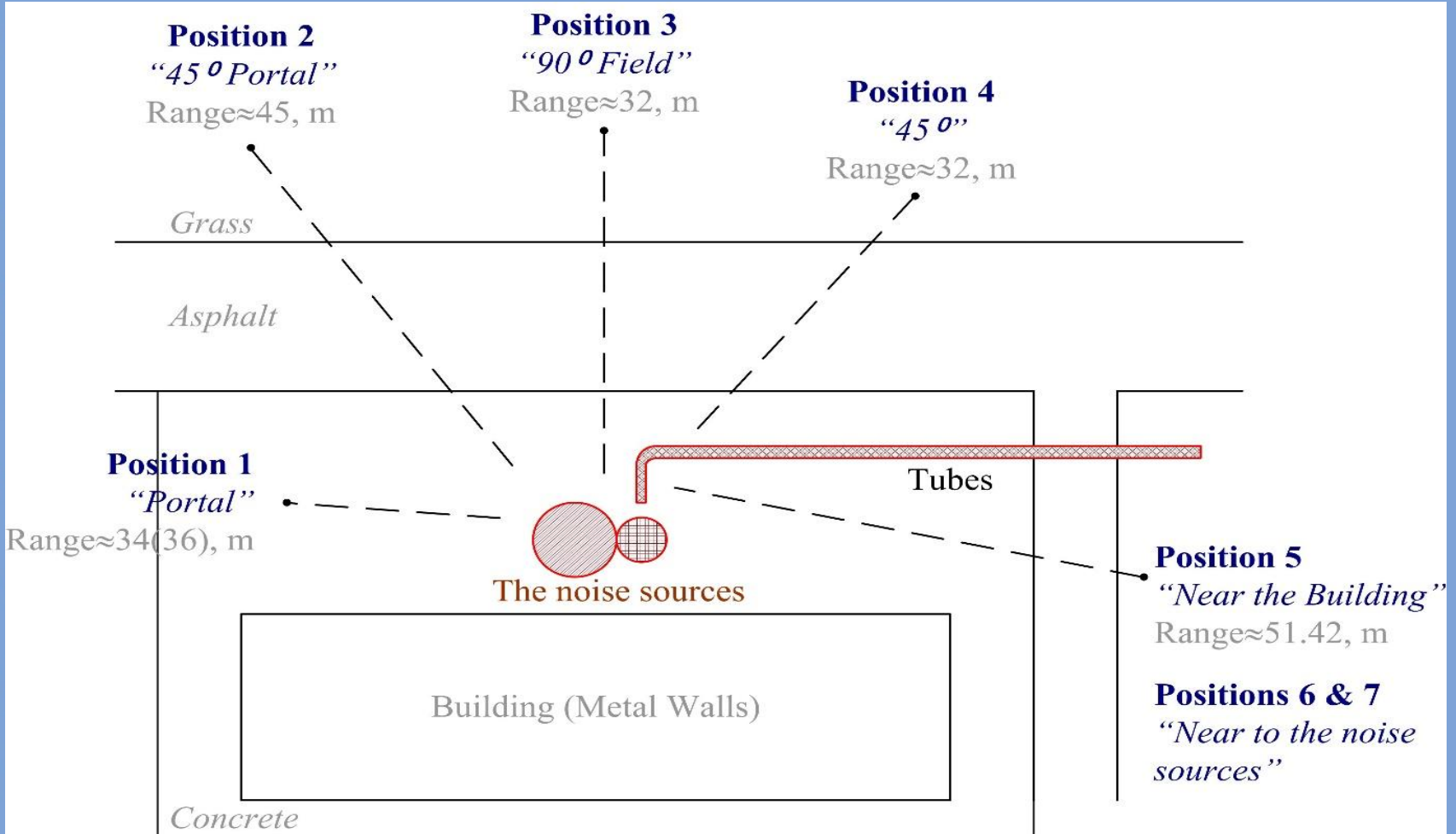

Position 1

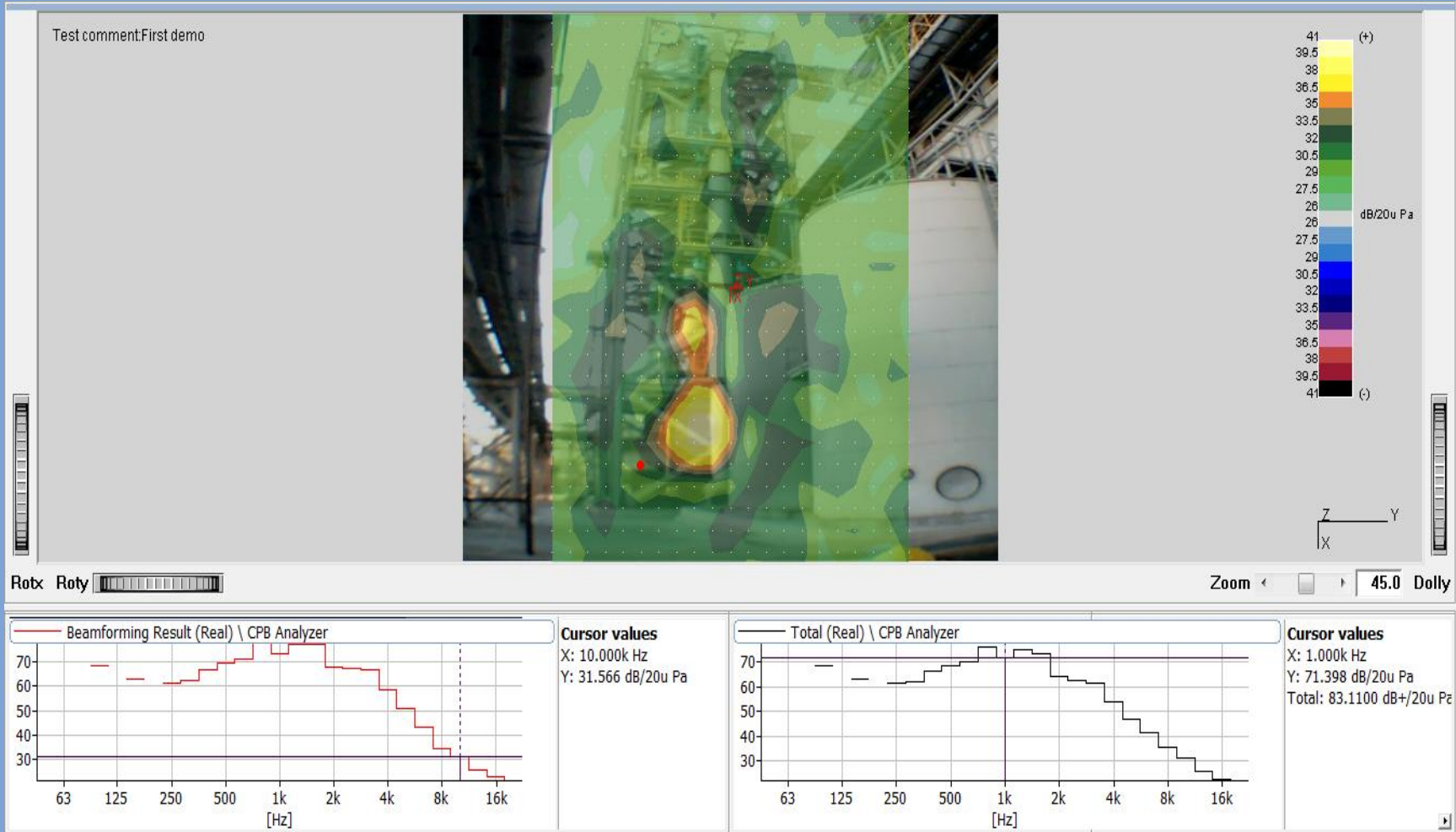

Position 2

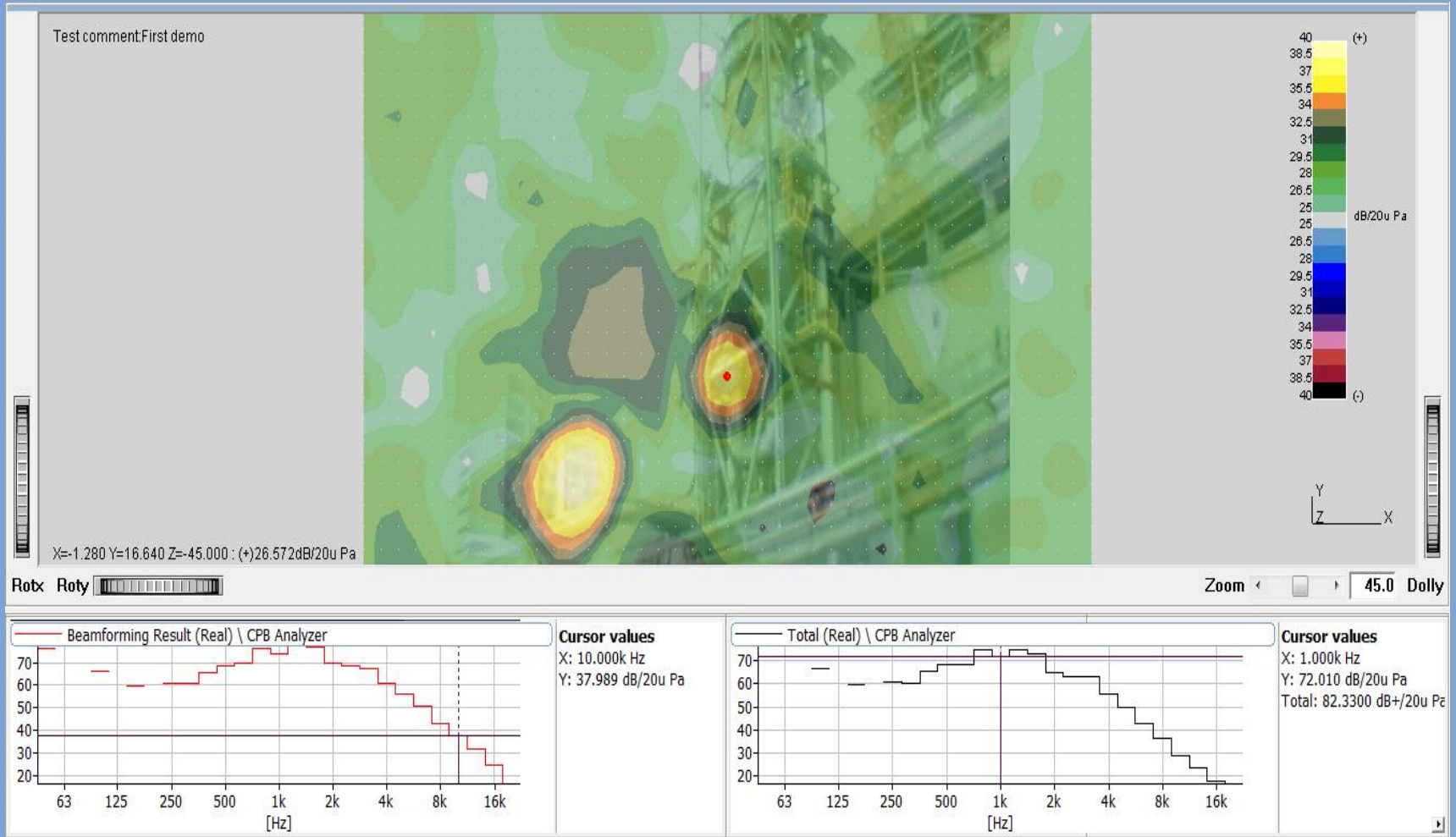

Position 3

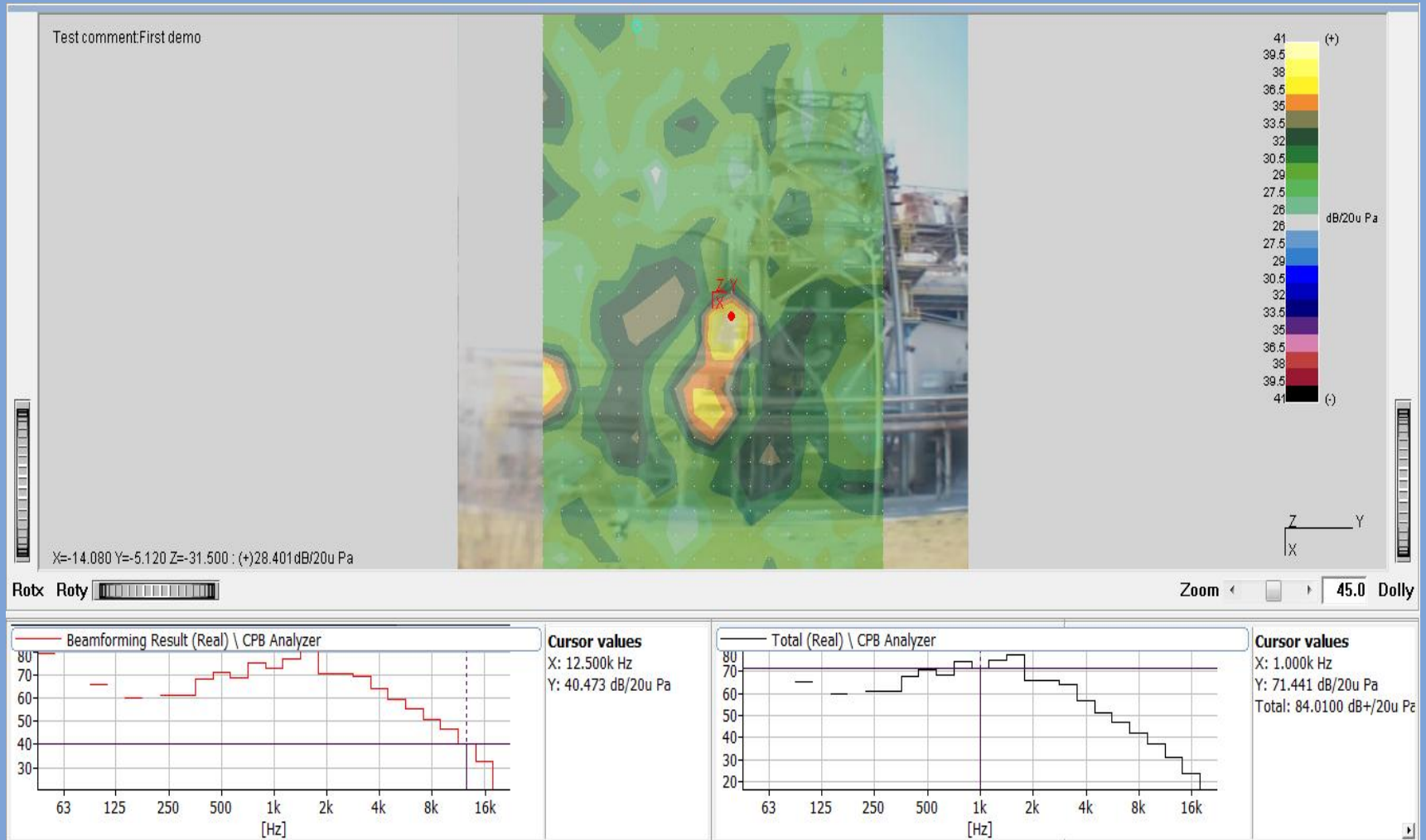

Position 4

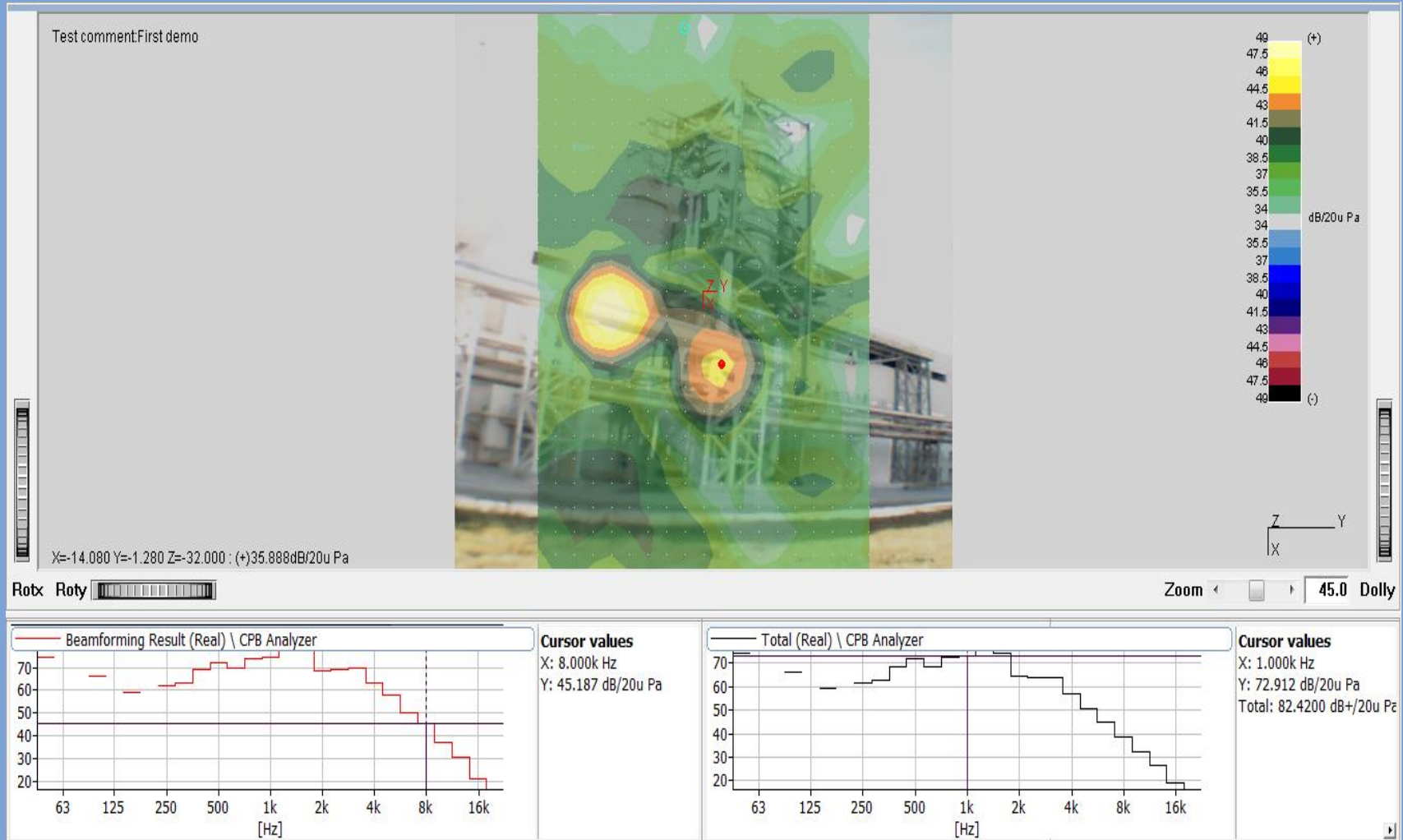

Position 5

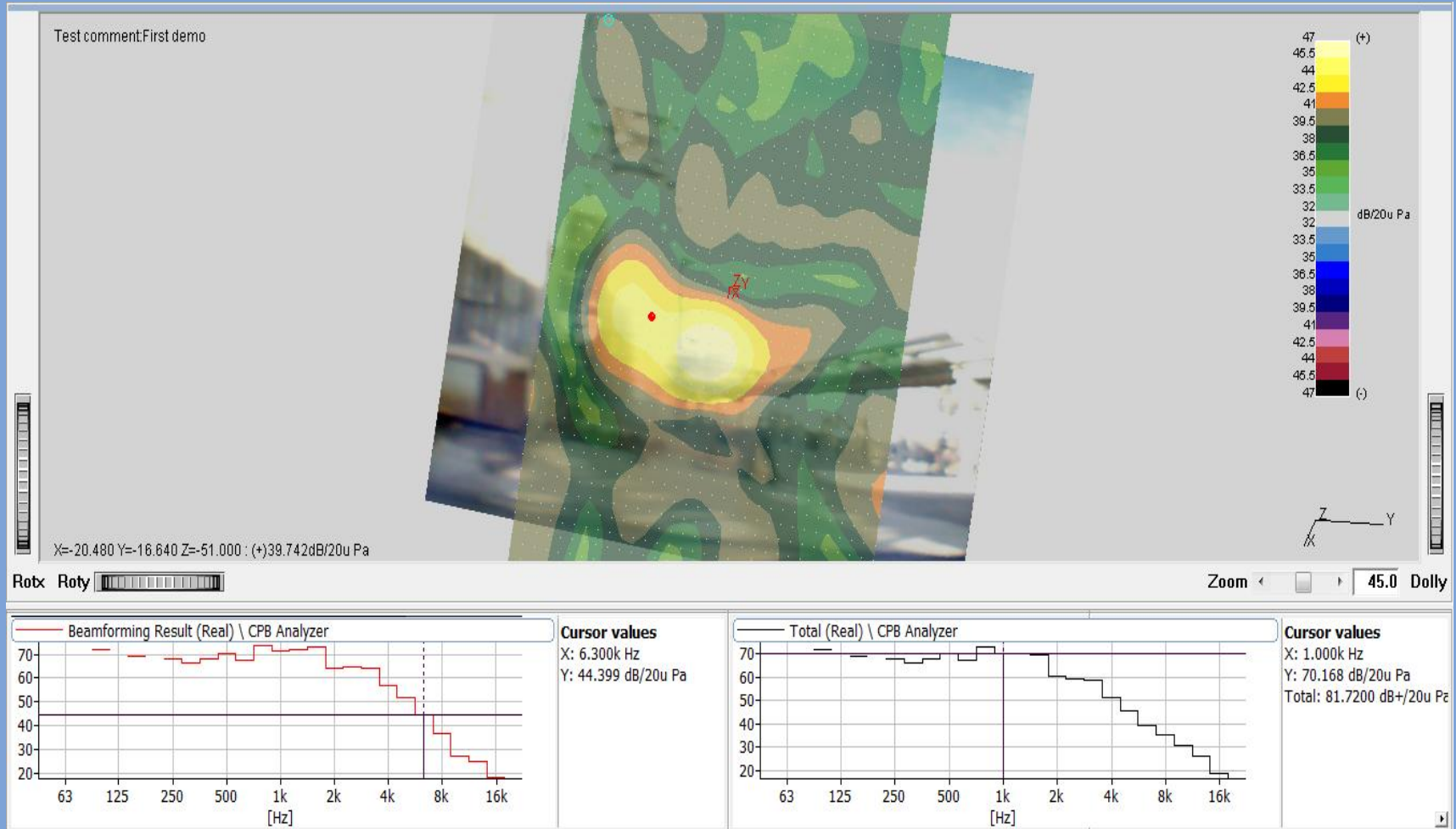



Summary

The sources of the noise are accurately localized and measured. This information will help acoustic engineers to find effective solution for noise reduction.

Summary

The detected main noise sources are as following: (i) the motor, (ii) the horizontal pipeline and (iii) the horizontal pipes of the installation, including the corner of the vertical pipe and the connection of the pipes.

The information is applicable to formulate a task for design of a cloak for suppression of the acoustic noise of the installation. Additionally, the information may be used to check quality of the developed/installed cloak.

Arena “Armeec” hall



Arena “Armeec” hall



Arena “Armeec” hall

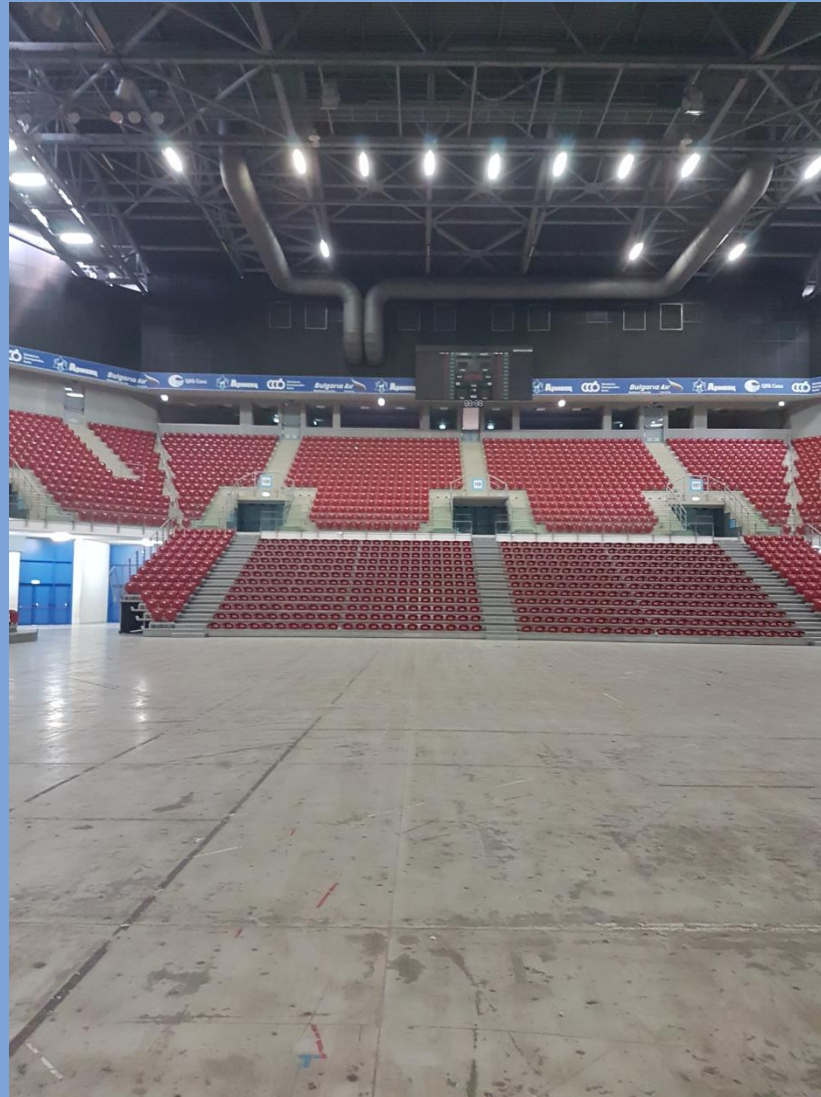

The problem

The hall will be used for 2018 Rhythmic Gymnastics World Championships, the 36th edition, from 10 September to 16 September 2018 and since 21 September 2018 FIVB Volleyball Men's World Championship Italy-Bulgaria.

Its acoustics has to respond in the first case to the requirement of music halls, and in the second case to the requirement of sport events.

Optimal reverberation time

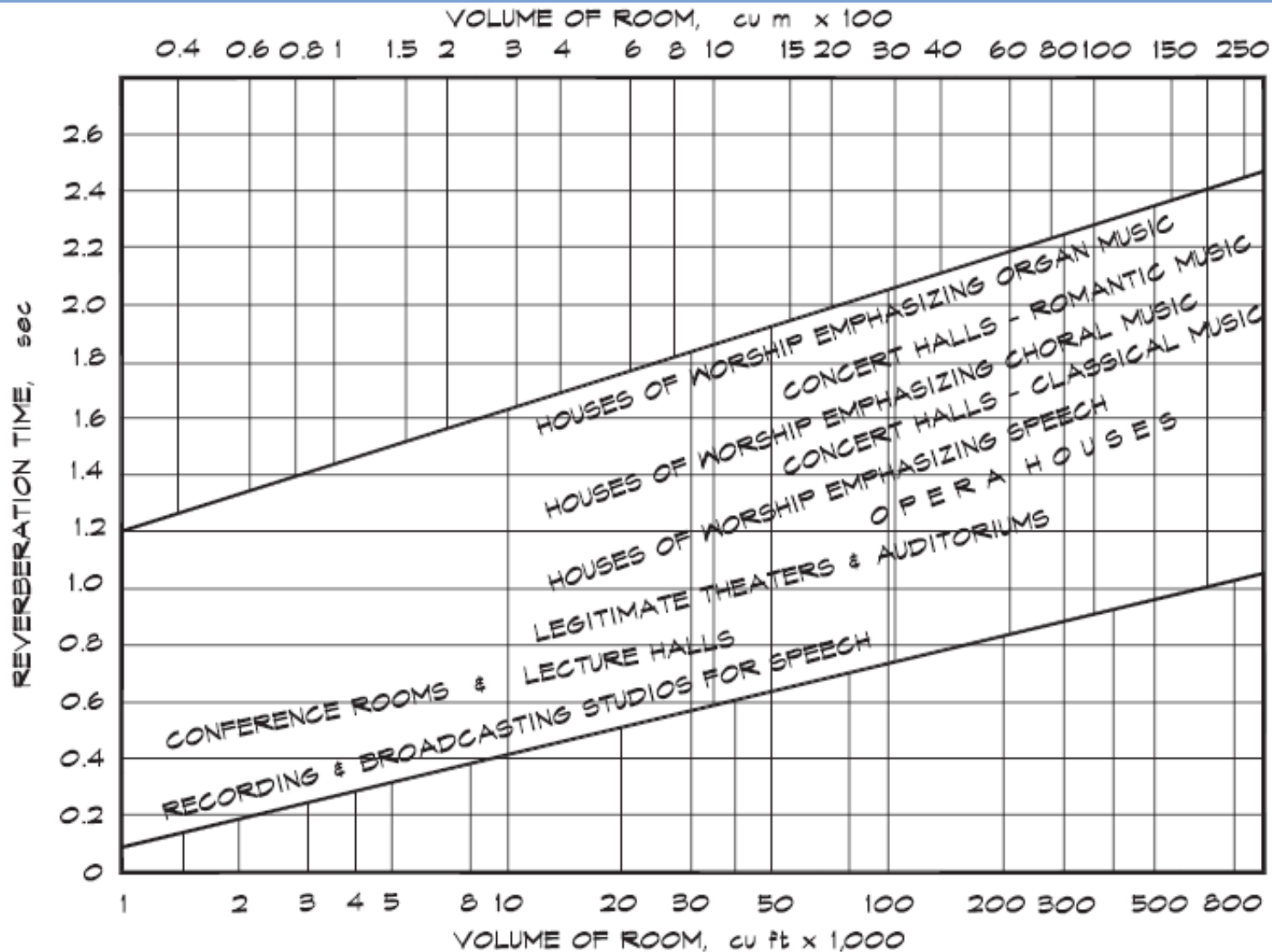

Arena Armeec ceiling

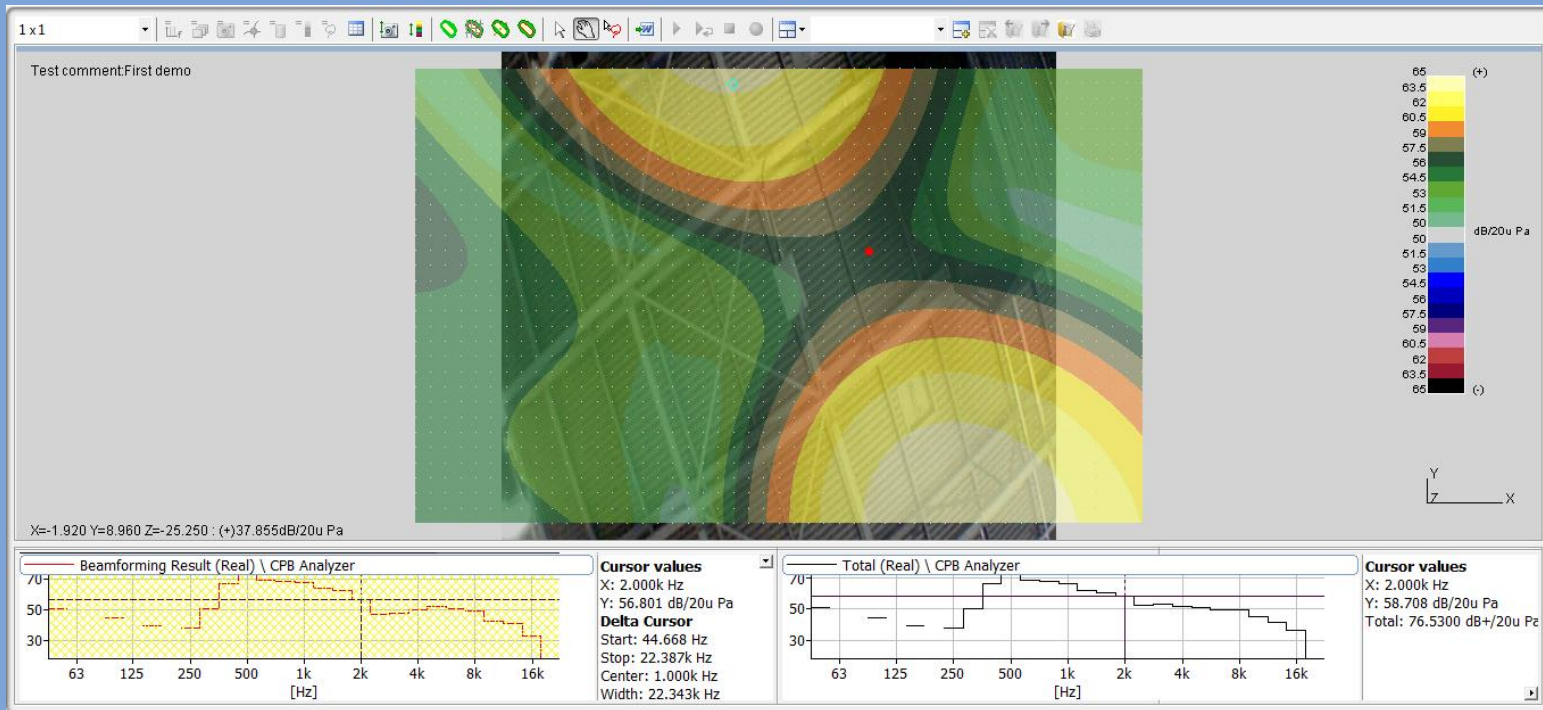

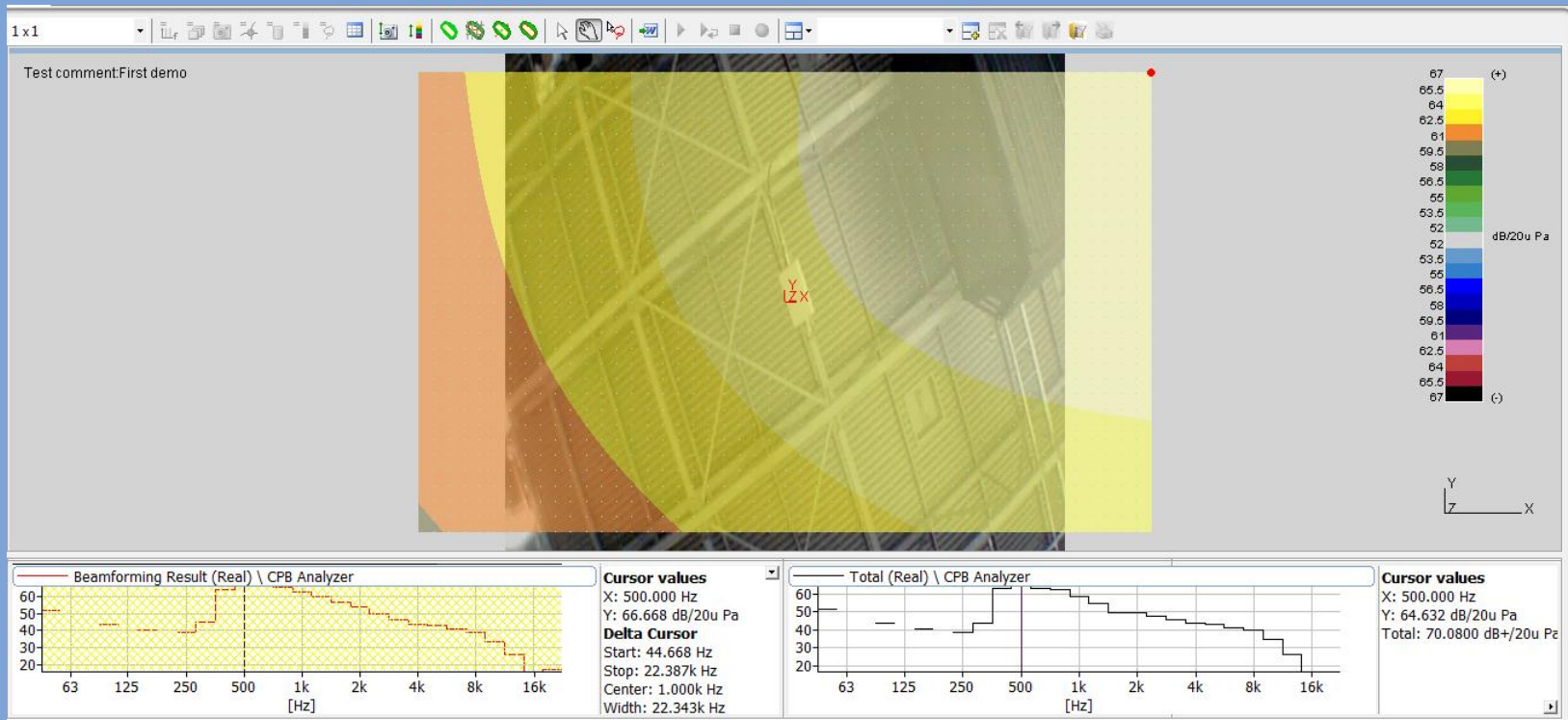

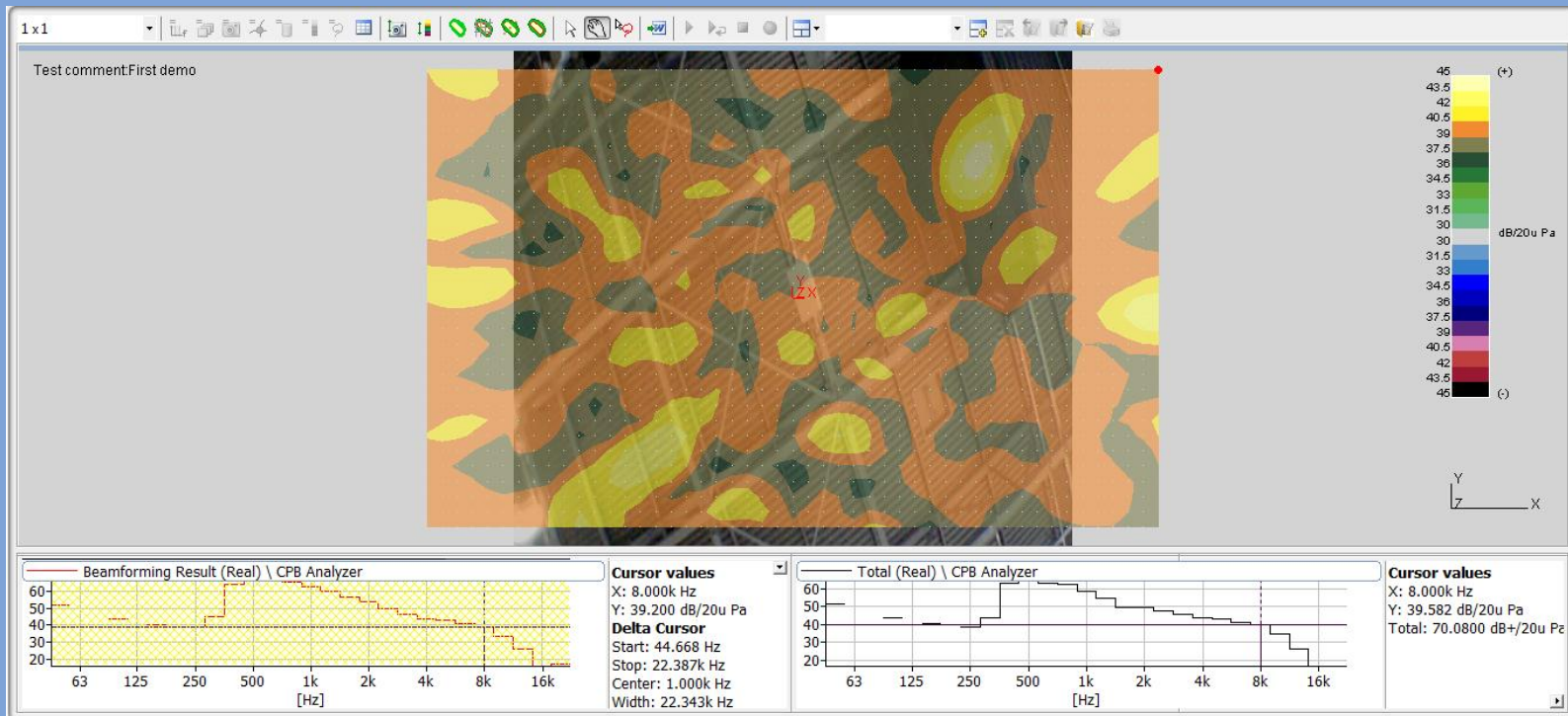

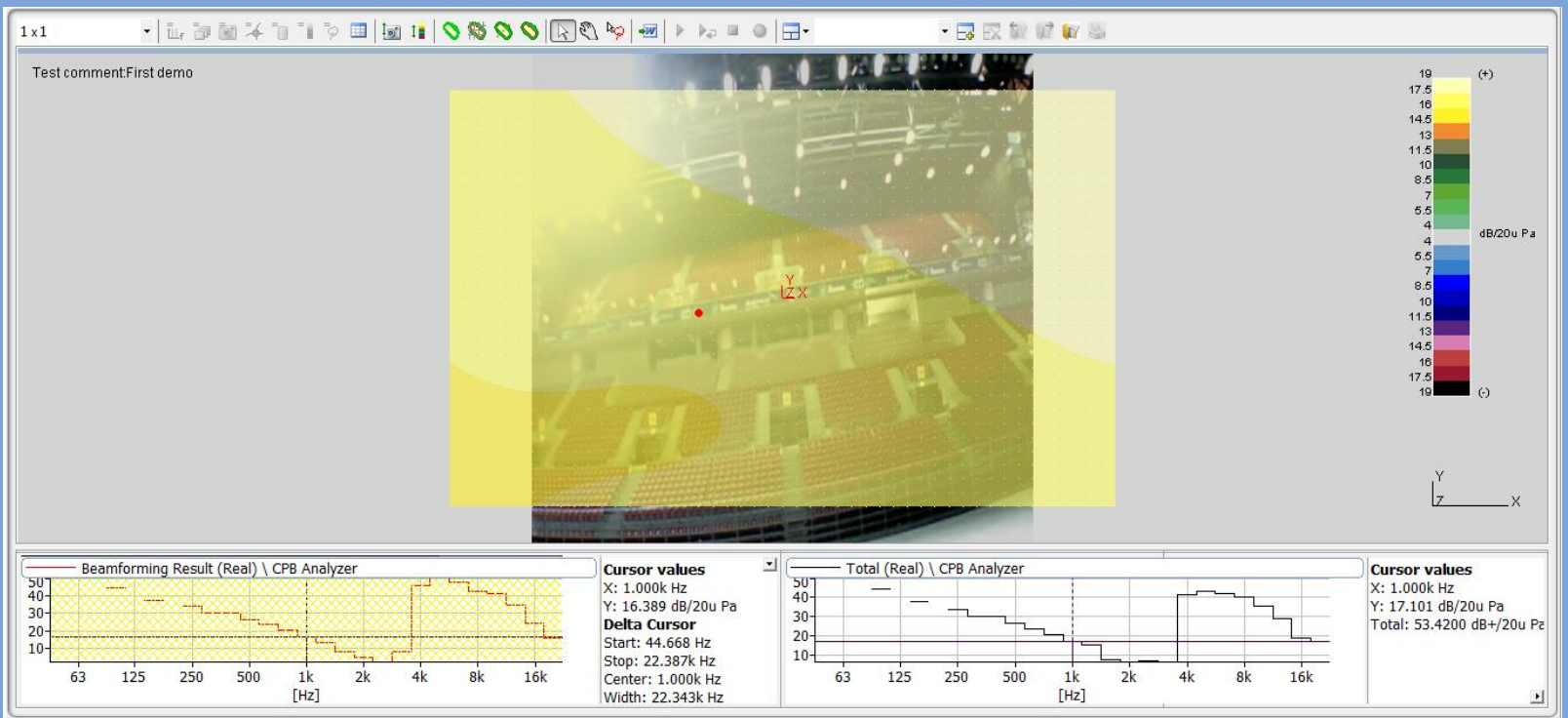

tribune

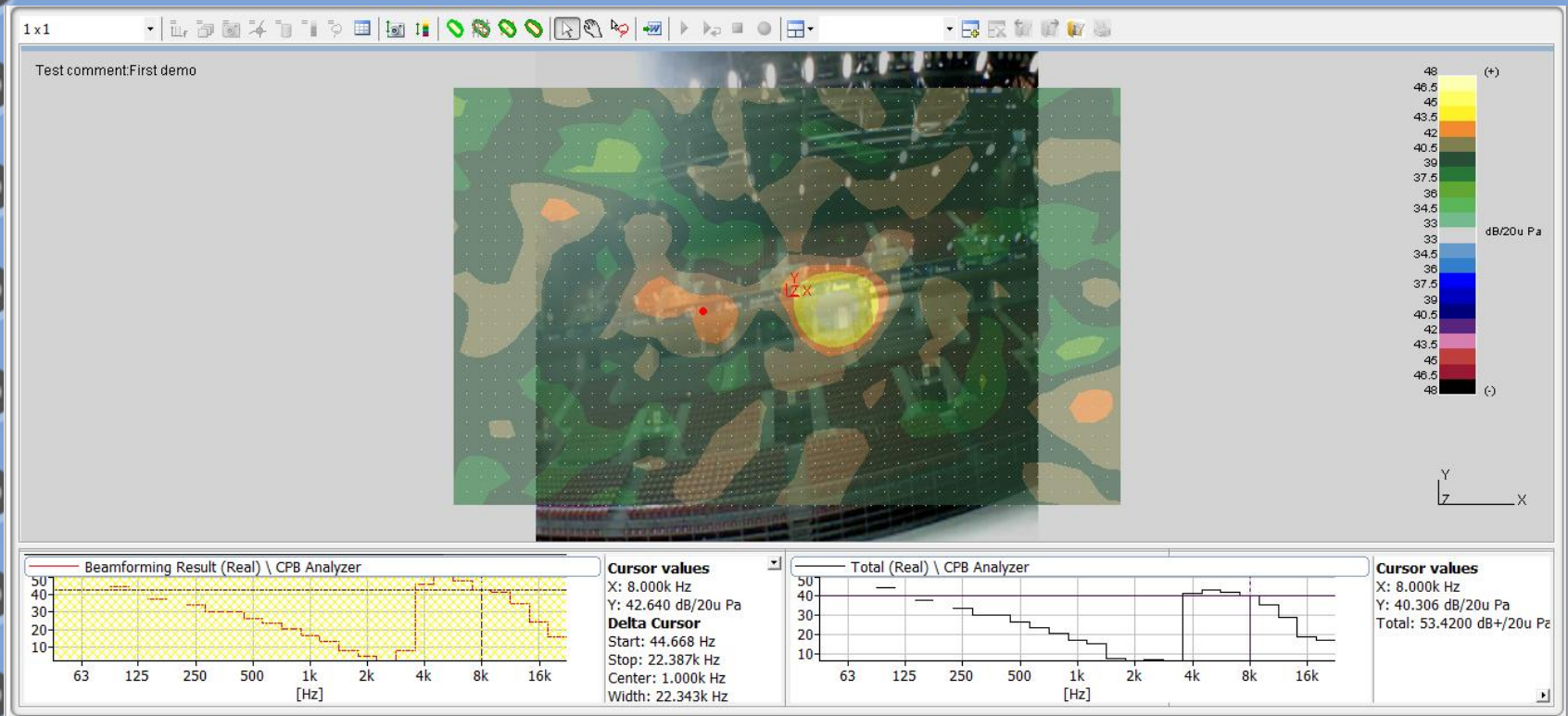

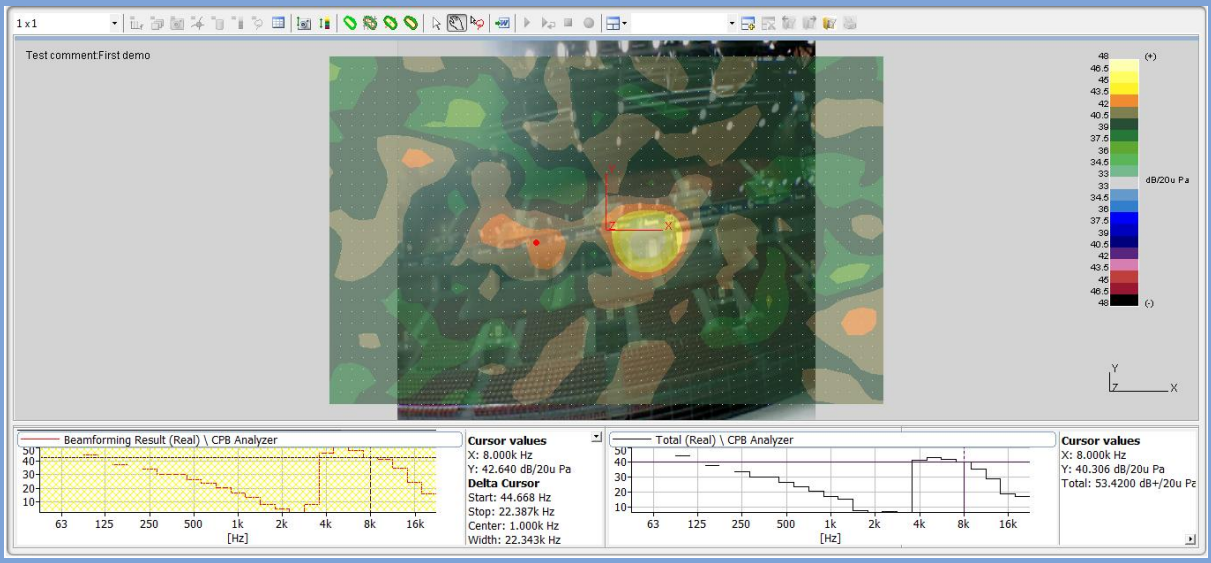

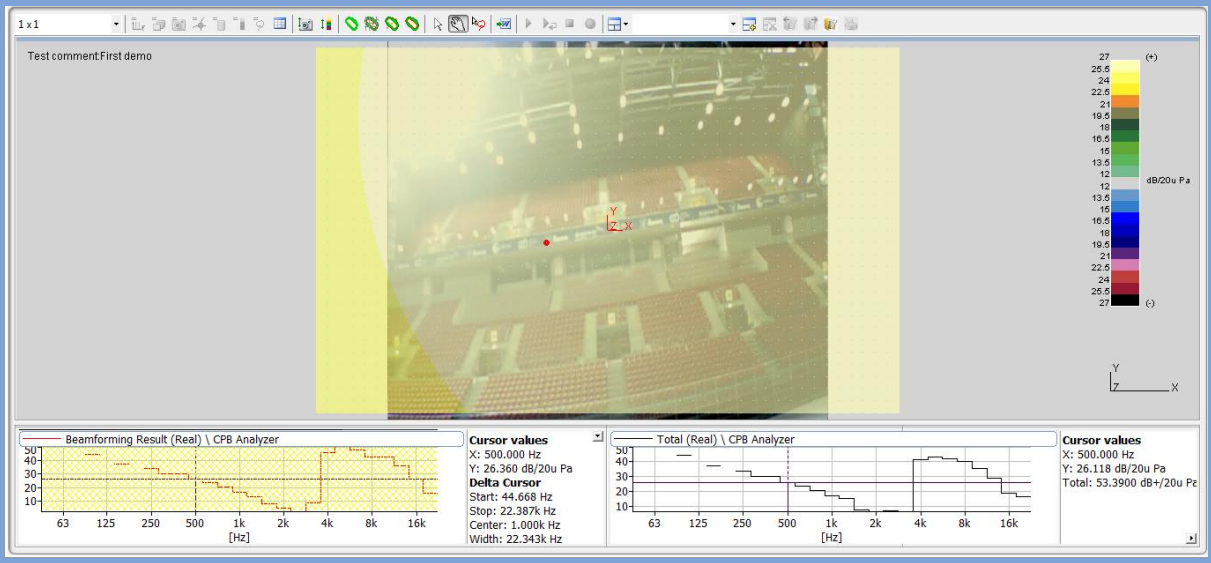

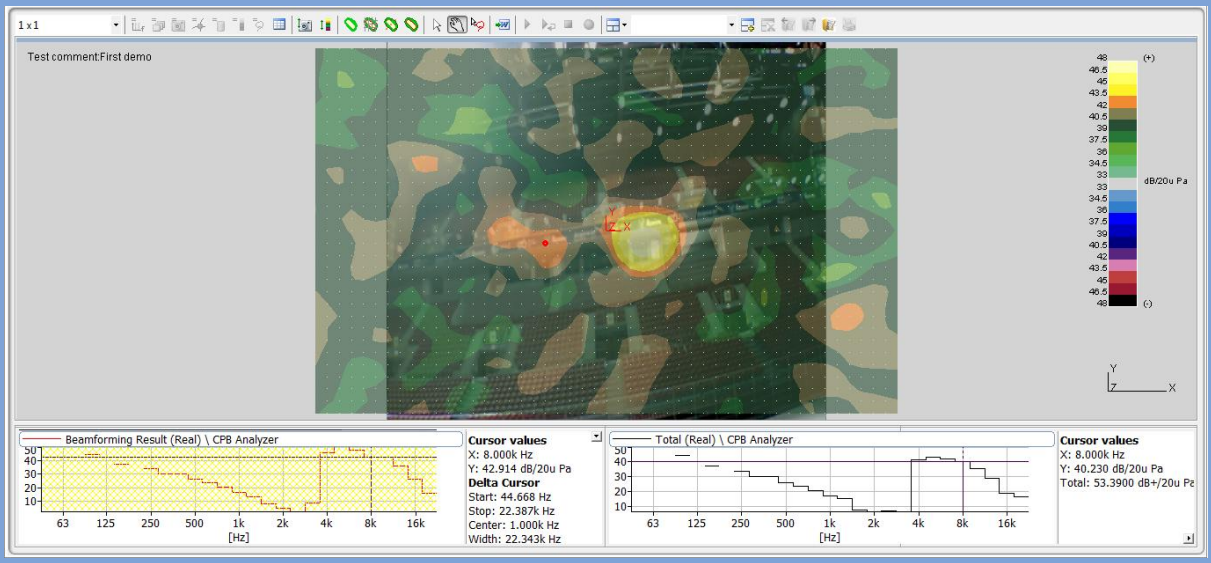

Summary

The measured reverberation time is about 3 times greater than recommended one for Rhythmic Gymnastics World Championships and it is absolutely suitable for Volleyball Men's World Championship. The most appropriate engineering solution to enhance the acousic of the hall for the first case is to switch off the general hall acoustic system and to accommodate local one near to the gymnastics carpet. There were recommended some actions in order to reduce acoustic reflection.

